















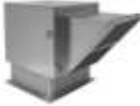

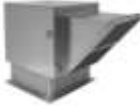







# Index

	Page		
<b>Roof-Exhaust-Centrifugal-Aluminum</b>			
Direct Drive Mushroom Style TKS	3		
Direct Drive Mushroom Style DR	4		
Direct Drive Upblast DU	5		
Belt Drive Mushroom BDCR	7		
Belt Drive Upblast BDU	8-9		
<b>Roof Exhaust Axial</b>			
Direct Drive Mushroom DDAR	6		
Upblast Axial RB	10		
Hooded Belt-Drive Exhaust/Supply RH	11		<b>DISCONTINUED</b>
Belt Drive Hooded Axial HHC	12		
<b>Roof Supply Axial</b>			
Hooded Belt-Drive Exhaust/Supply RH	11		<b>DISCONTINUED</b>
Belt Drive Hooded Axial HHC	12		
Direct Drive Mushroom DMUA	13		
<b>Roof Filtered Supply Air NSA</b>	14		
<b>Roof Curbs-Curb Adaptors</b>	15		
<b>Wall Exhaust Centrifugal Aluminum</b>			
Direct Drive Mushroom Style DR	4		
Direct Drive Upblast DU	5		
Belt Drive Mushroom BDCR	7		
Belt Drive Upblast BDU	8-9		
<b>Wall Exhaust Axial (steel)</b>			
Direct Drive with shutter & switch CE	16		
Direct Drive Shutter Fan S-Series	17		
Belt Drive STD Duty VI	18		
Belt Drive Heavy Duty HV	19		
Direct Drive Heavy Duty DDS	20		
<b>Wall Supply Axial Steel</b>			
Belt Drive Heavy Duty HV	17		
Belt Drive Std Duty VI	18		
<b>Ceiling Cabinet (Bathroom fan) CFA</b>	21		
<b>In Line Fans &amp; Blowers</b>			
Direct Drive Duct Booster CK Series	22		
Direct Drive Square in line DSQD	23		
Belt Drive Square In Line DSQB	24		
Belt Drive Duct Fan Std Duty D-200	25		
Belt Drive Duct Fan Heavy Duty 9200	26		
Belt Drive Tube Axial TAB	27		
<b>Roof Vents Supply &amp; Exhaust</b>			
Economy EMUA	29		
Custom Sized VR-10 VS-10	30		

Backward Inclined Belt Drive Blower BI

28



Fixed Louvers-Galvanized /Aluminum

[Specifications](#)

31

[Performance/Free Area](#)

32

[Price](#)

33



Operable Louvers-Galvanized/Aluminum

[Specifications](#)

34

[Performance/Free Area](#)

35

[Price](#)

36



Air Control Damper

[Specifications](#)

37

[Performance/Price](#)

38



Economy Back Draft Damper

[Specifications](#)

39

[Performance/Price](#)

40



Backdraft-Shutters Counter Balance Gravity

[Specifications](#)

41

[Performance/Price](#)

42



Actuator Selection Guide

43

Wall Fan Shutters

44



Electric Duct Heaters

[DB-DC Series](#)

45



# SMALL CENTRIFUGAL ROOF FAN - TKS SERIES

- ROOF CURB MOUNTED
- BLACK POLYESTER FINISH
- 115 VOLT TOTALLY ENCLOSED MOTOR
- VARIABLE SPEED
- BACKWARD INCLINE WHEEL
- HINGED MOTOR/WHEEL ASSEMBLY
- PERFECT FOR SMALL ROOMS



MODEL	WATTS	AMPS	DB* @ DUCT	SPEED RPM	CFM @ SP"				LIST PRICE	ROOF CURB		SPEED CONTROL		BD DAMPER					
					0	0.125	0.25	0.5		12"H MODEL / LIST		AMP / LIST		MODEL / LIST					
TKS-300 A	44	0.39	57	1600	165	153	112	60	\$323	POD-11.5	\$75	3 AMP	\$44	RSK 6"	\$75				
TKS-300 B	64	0.56	65	1945	210	180	155	110	\$332					RSK 8"	\$75				
TKS-300 C	75	0.68	68	2470	250	235	205	165	\$367	POD-15.5	\$80	3 AMP	\$44						
TKS-400 A	88	0.79	70	2120	400	350	325	235	\$427										
TKS-400 B	132	1.16	75	2645	495	480	425	370	\$440										
TKS-400 C	2.5	1.89	73	2715	600	590	550	500	\$477										

\*NOT RECOMMENDED FOR LINE OF SIGHT APPLICATIONS.  
 USE INSULATED ELBOWS OR INSULATED ROUND DUCT WHEN NECESSARY  
 \*\*ROUND BACK DRAFT DAMPERS (DIAMETER GIVEN)

MODEL	DIMENSIONS (IN)			
	A	B	C	D
TKS 300	13.39	7.8	12.01	1.18
TKS 400	17.72	8.07	16.33	1.18

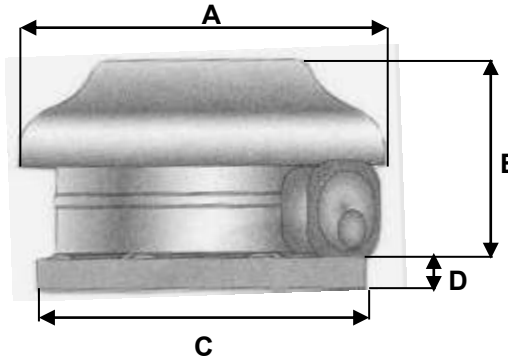

# DIRECT DRIVE ROOF & WALL CENTRIFUGAL FANS - DR SERIES

## FEATURES:

- \* ROOF OR WALL MOUNTED
- \* SPUN ALUMINUM CONSTRUCTION
- \* DOWNBLAST DISCHARGE
- \* VARIABLE SPEED MOTORS
- \* DR INCLUDES SPEED CONTROL/DISCONNECT SWITCH
- \* NON CLOGGING BACKWARD INCLINED WHEEL
- \* BIRDSCREEN INCLUDED



MODEL #	HP	MAX RPM	CFM @ SP.						WT LBS	1 PHS 115 V	CURB 12"H MODEL / LIST		BD DAMPER MODEL / LIST	
			1/8"	1/4"	3/8"	1/2"	5/8"	3/4"						
DR10H	1/15	1600	490	442	394	342	275	197	30	\$442	POD-17.5	\$87	I-12	\$50
DR12H	1/7	1400	685	606	522	432	337	243	35	\$543				
DR30H	1/4	1700	1362	1314	1265	1211	1157	1094	45	\$662	POD-19.5	\$97	I-15	\$64
DR50H	1/2	1650	2488	2410	2333	2244	2156	2066	50	\$776				
DR85H	3/4	1650	3317	3235	3154	3072	2983	2890	60	\$960	POD-23	\$109	I-19	\$80

AVAILABLE IN 5 WORK DAY FROM THE FACTORY

DIMENSIONS				ROOF OPEN
MODEL	A	B	C	
DR10H	20-3/4	12-1/2	19	13X13
DR12H	23-3/4	14-1/4	19	13X13
DR25H	26-1/4	17-1/8	21	16X16
DR30H	26-1/4	17-1/8	21	16X16
DR50H	29-3/4	19-3/4	21	16X16
DR85H	33-1/4	21-3/8	24-3/4	20X20

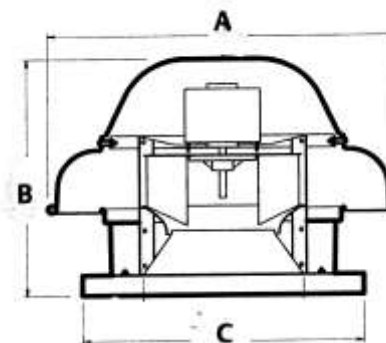

# DIRECT DRIVE CENTRIFUGAL UPBLAST - DU SERIES

## ROOF OR WALL APPLICATIONS

### FEATURES

- \* VARIABLE SPEED CONTROL STANDARD
- \* WALL OR ROOF MOUNTING
- \* QUICK LATCH COVER
- \* EXTERNAL WIRED DISCONNECT SWITCH
- \* LEAK PROOF DRAIN
- \* UL-762 COMPLIANCE (EXCEPT DU-10H)



DELUX MODELS	HP	MAX RPM	CFM @ SP						WT LBS	1PH 115V	3PH 230/460V	CURB 12"H MODEL / LIST		DAMPER MODEL / LIST	
			1/8"	3/8"	1/2"	5/8"	3/4"	1"							
DU10H	1/15	1600	493	398	343	280	204	--	30	\$518	--	POD-17.5	\$87	I-12	\$50
DU12H	1/7	1500	705	567	481	385	294	--	50	\$707	--				
DU30H	1/4	1600	1201	1080	1016	942	864	677	50	\$824	--	POD-19.5	\$97	I-15	\$64
DU33H	1/3	1725	1290	1181	1116	1051	984	831	50	\$857	\$957				
DU50H	1/2	1670	2116	1987	1922	1854	1786	1615	55	\$931	\$1,043				
DU85H	3/4	1625	3306	3144	3063	2969	2875	2685	60	\$1,135	\$1,136	POD-23	\$109	I-19	\$80

AVAILABLE FROM THE FACTORY IN 5 WORK DAYS

\*\*REQUEST 18" HI CURB WHEN OVER  
A COOKING SURFACE

DIMENSIONS		DU SERIES					
FAN SIZE	W	HT	C	ROOF OPEN	CURB OD	WT	
10	17.8	14.5	19	13	17.5	30	
12	22	18	19	13	17.5	40	
25	25.5	25.3	21	16	19.5	50	
30	25.5	25.3	21	16	19.5	50	
33	25.5	25.3	21	16	19.5	50	
50	28.9	27.3	21	16	19.5	55	
75	31.9	30.5	24.8	20	23	60	
85	31.9	30.5	24.8	20	23	60	

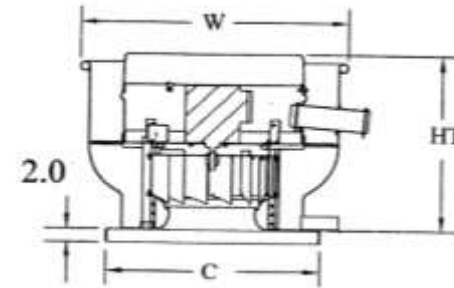

# EXHAUST FAN - AXIAL ROOF-WALL - DDAR SERIES

## Direct Drive - Low Profile

**FEATURES:**

- \* SPUN ALUMINUM HOUSING
- \* LOW PROFILE
- \* ROOF OR WALL MOUNTED
- \* 115 VOLT - TOTALLY ENCLOSED MOTOR
- \* DISCONNECT SWITCH
- \* BIRD SCREEN
- \* 5 DAY LEAD TIME



MODEL	HP	RPM	CFM @ SP			EST LBS	FAN LIST	CURB		DAMPER	
			1/8"	1/4"	3/8"			MODEL / LIST	MODEL / LIST		
DDAR-10	1/30	1500	339	267	173	24	\$300	POD-17.5	\$87	I-12	\$50
DDAR-12	1/10	1500	710	620	522	32	\$384	POD-17.5	\$87	I-12	\$50
DDAR-14	1/6	1500	599	786	646	45	\$494	POD-19.5	\$97	I-15	\$64
DDAR-18	1/3	1500	2034	1628	1491	67	\$682	POD-24.5	\$112	I-19	\$80

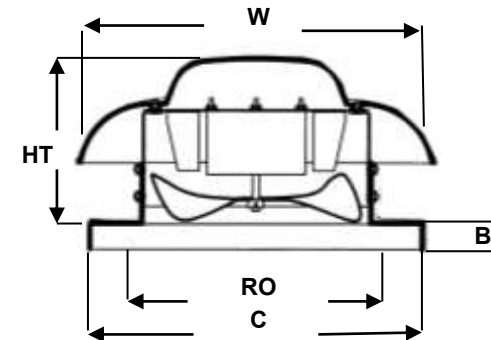

MODEL	HT	W	B	C	D	E	RO	SHIP LBS	DAMPER SQ
DDAR 10	9 3/4	18 5/6	2	19	17 1/2	12	13	24	12
DDAR 12	10 1/4	20 5/6	2	19	17 1/2	12	13	32	12
DDAR 14	12 5/8	27 1/3	2	21	19 1/2	12	16	45	15
DDAR 18	14 3/8	33 9/16	2	26	24 1/2	12	20	67	19

# BELT DRIVE CENTRIFUGAL ROOF FAN - BDCR SERIES

## FEATURES:

- \* COMPLETELY ASSEMBLED
- \* DISCONNECT SWITCH MOUNTED & WIRED
- \* LATCH RELEASE COVER
- \* VARIABLE PITCH PULLEY
- \* BACKWARD INCLINED WHEEL
- \* VIBRATION ISOLATION
- \* FAN COOLED MOTOR COMPARTMENT



MODEL #	HP	FAN RPM	CFM @ SP					1 PH 115/230	3 PH 230/460	EST LBS	CURB 12"H		DAMPER	
			1/4	1/2	3/4	1	1-1/4				MODEL / LIST	MODEL / LIST		
BDCR-70	1/4	1683	750	650	550	450	350	\$797	---	90	POD-19.5	\$97	I-15	\$64
BDCR-80	1/4	1684	751	651	551	451	---	\$796	---	91				
BDCR-110	1/4	1415	1300	1100	900	---	---	\$773	---	105				
BDCR-111	1/3	1676	1500	1300	1100	900	900	\$785	---	105				
BDCR-130	1/4	1170	1700	1500	1300	1100	---	\$819	---	105				
BDCR-131	1/3	1282	1900	1700	1500	1300	---	\$831	---	110				
BDCR-132	1/2	1512	2300	2100	1900	1500	---	\$851	\$876	115				
BDCR-151	1/3	1028	2400	2000	1600	---	---	\$894	---	135	POD-23	\$109	I-19	\$80
BDCR-152	1/2	1168	2800	2400	2000	1600	---	\$914	\$939	140				
BDCR-153	3/4	1334	3200	2800	2400	2000	2000	\$943	\$948	145				
BDCR-154	1	1524	3600	3600	3200	2800	2400	\$984	\$962	150				
BDCR-183	3/4	988	3600	3200	2800	2400	---	\$1,320	\$1,333	190	POD-26.5	\$115	I-23	\$96
BDCR-184	1	1084	4000	3600	3200	2800	2400	\$1,368	\$1,350	195				
BDCR-185	1-1/2	1278	4800	4400	4000	4000	3600	\$1,426	\$1,377	200				
BDCR-186	2	1376	5200	4800	4800	4400	4000	\$1,654	\$1,570	205				
BDCR-203	3/4	843	4500	4000	3500	---	---	\$1,336	\$1,341	200				
BDCR-204	1	924	5000	4500	4000	3500	---	\$1,382	\$1,357	205				
BDCR-205	1-1/2	1089	6000	5500	5000	4500	4000	\$1,453	\$1,384	210				
BDCR-206	2	1172	6500	6000	6000	5500	5000	\$1,778	\$1,611	215				
BDCR-244	1	690	6000	5000	4000	3000	---	\$1,795	\$1,769	220	POD-31.5	\$130	I-27	\$104
BDCR-245	1-1/2	786	7000	6000	6000	5000	4000	\$1,874	\$1,798	225				
BDCR-246	2	885	8000	7000	7000	6000	5000	\$2,170	\$2,048	230				
BDCR-247	3	986	9000	9000	8000	8000	7000	\$2,560	\$2,127	235				
BDCR-306	2	589	9000	9000	8000	7000	6000	\$2,656	\$2,497	390	POD-39	\$158	I-35	\$131
BDCR-307	3	705	11000	10000	10000	9000	8000	\$2,868	\$2,567	395				
BDCR-308	5	823	13000	13000	12000	12000	11000	---	\$2,802	400				
BDCR-366	2	449	12000	10000	8000	---	---	\$3,659	\$3,508	425	POD-42.5	\$170	I-39	\$192
BDCR-367	3	512	14000	12000	12000	10000	---	\$3,955	\$3,587	430				
BDCR-368	5	641	18000	16000	16000	14000	12000	---	\$3,851	435				

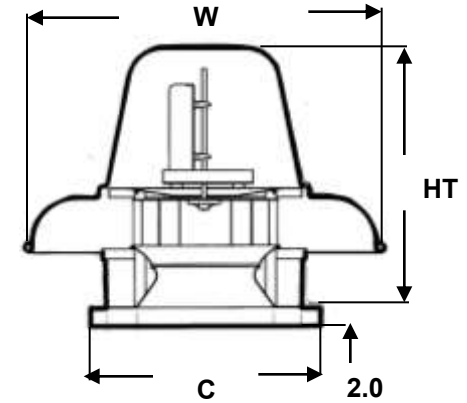

BDCR Dimensions						
Fan Sizes	W	HT	C	Roof Open	Curb OD	Ship WT
7	26	25.5	21	16	19.5	90
8	26	25.5	21	16	19.5	90
11	26	25.5	21	16	19.5	105
13	30	27.3	21	16	19.5	105
15	33	30.6	24.8	20	23.3	130
18	38	32.8	18	24	26.5	190
20	38	32.8	28	24	26.5	195
24	43	37.8	33	28	31.5	215
30	52	40	40	36	34.5	380
36	66	43	44.5	36	34.5	420

AVAILABLE IN 5 WORK DAYS FROM FACTORY

Intermediate sized available -- Contact the "Fan Dept"

# BELT DRIVE UPBLAST CENTRIFUGAL EXHAUSTER - BDU SERIES

## FEATURES

- \* COMPLETELY ASSEMBLED
- \* DISCONNECT SWITCH MOUNTED & WIRED
- \* VARIABLE PITCH PULLEY
- \* QUICK LATCH COVER
- \* VIBRATION ISOLATION
- \* LEAK PROOF GREASE DRAIN
- \* FAN COOLED MOTOR COMPARTMENT
- \* UL-762 COMPLIANCE



MODEL	HP	MAX RPM	CFM @ SP					WT LBS	1 PHASE 115/230	3 PH 230/460	CURB 18"H		WALL MOUNT	GREASE CUP
			1/4"	1/2"	3/4"	1"	1 1/4"				MODEL / LIST			
BDU-11	1/4	1520	1200	1000	800	800	---							
BDU-11	1/3	1650	1400	1200	1000	1000	---	105	\$1,084	---				
BDU-11	1/2	1880	1600	1600	1400	1200	1000		\$1,111	\$1,101	POD-19.5	\$145	\$79	\$57
BDU-13	1/4	1130	1600	1400	1200	---	---		\$1,117	---				
BDU-13	1/3	1300	1800	1600	1400	---	---	120	\$1,122	---				
BDU-13	1/2	1490	2200	2000	1800	1600	1200		\$1,137	\$1,131				
BDU-15	1/3	1030	2200	2000	1600	---	---		\$1,151	---				
BDU-15	1/2	1180	2800	2400	2000	1800	---	140	\$1,166	\$1,160	POD-23	\$164	\$79	\$57
BDU-15	3/4	1380	3200	3000	2600	2400	2000		\$1,190	\$1,173				
BDU-15	1	1500	3600	3400	3200	2800	2600		\$1,236	\$1,193				
BDU-18	3/4	978	3500	3000	3000	2500	---		\$1,356	\$1,337				
BDU-18	1	1050	4000	3500	3500	3000	2500	190	\$1,401	\$1,358	POD-26.5	\$172	\$79	\$57
BDU-18	1-1/2	1248	4500	4500	4000	4000	3500		\$1,482	\$1,396				
BDU-18	2	1420	5000	5000	4500	4500	4000		\$1,803	\$1,611				
BDU-20	1	900	4700	4200	3700	3200	---		\$1,661	\$1,617				
BDU-20	1-1/2	1080	5700	5200	4700	4700	4200	195	\$1,736	\$1,656	POD-26.5	\$172	\$79	\$57
BDU-20	2	1210	6200	6200	5700	5200	4700		\$2,026	\$1,870				

(CONTINUED ON PAGE 9)



MODEL	LEAD TIME	HP	MAX RPM	CFM @ SP					WT LBS	1 PH 115/230	3 PH 230/460	CURB 18"H		WALL MOUNT	GREASE CUP
				1/4"	1/2"	3/4"	1"	1 1/4"				MODEL / LIST			
BDU-24	B	1	730	5500	4500	4500	3500	---	270	\$1,966	\$1,922	POD-31.5	\$195	\$81	\$57
BDU-24		1 1/2	776	6500	6500	5500	4500	---		\$2,041	\$1,960			\$81	
BDU-24		2	900	7500	7500	6500	5500	5500		\$2,319	\$2,175			N/A	
BDU-24		3	1000	9500	8500	7500	7500	6500		\$2,731	\$2,223			N/A	
BDU-24		5	1170	10500	10500	9500	9500	8500		---	\$2,455			N/A	
BDU-30	B	1 1/2	580	8000	7000	6000	---	---	410	\$3,068	\$2,926	POD-38.5	\$237	N/A	\$57
BDU-30		2	630	9000	8000	8000	7000	6000		\$3,352	\$3,183				
BDU-30		3	700	11000	10000	9000	9000	8000		\$3,681	\$3,273				
BDU-30		5	842	13000	12000	12000	11000	10000		\$3,873	\$3,558				
BDU-36	B	2	426	12000	10000	---	---	---	470	\$4,403	\$4,248	POD-42.5	\$254	N/A	\$57
BDU-36		3	510	14000	14000	12000	10000	---		\$4,708	\$4,329				
BDU-36		5	645	20000	18000	16000	14000	12000		\$4,932	\$4,601				

AVAILABLE FROM THE FACTORY IN 5 WORK DAYS

### Centrifugal Up-Blast Fans

#### MEASUREMENTS

MODEL	HT	W	C	ROOF OPENING	WEIGHT LBS	DAMPER SQ
BDU11	25 1/4	27 1/4	21	16	105	15
BDU13	27 1/4	30 1/4	21	16	120	15
BDU15	30 1/2	33 3/4	24 3/4	20	140	19
BDU18	33 3/4	39 3/8	28	24	190	23
BDU20	33 3/8	38 7/8	28	24	195	23
BDU24	37 1/2	43 3/8	33	28	270	27
BDU30	40	52 3/4	40	36	410	35
BDU36	49 1/2	66	44 1/2	36	470	35 1/2

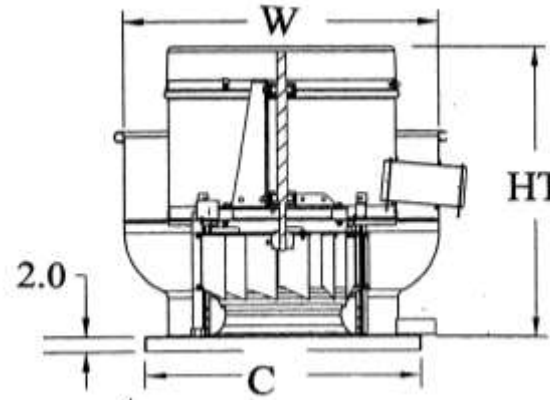

# UPBLAST ROOF AXIAL EXHAUSTER - RB SERIES

## FEATURES:

- \* HIGH VOLUME CFM
- \* QUIET BELT DRIVE\*\*
- \* TOTALLY ENCLOSED MOTORS
- \* LEAD TIME = 4 WEEKS
- \* ROOF CURBS AVAILABLE IN 8 WORK DAYS

MODEL #	AVG WT.	HP	FAN RPM	CFM @ SP						DBA @ 5	LIST PRICES		CURB MODEL / LIST	
				0"	BHP	1/8"	BHP	1/4"	BHP		1 PH TE 115/230V*	3 PH TE 230/460V*		
RB24T10075	330	3/4	1090	6261	0.65	5706	0.68	5135	0.73	72	\$3,774	\$3,568	POD-28	\$120
RB24T10100		1	1190	6836	0.84	6327	0.88	5893	0.93	74	\$3,852	\$3,622		
RB24T10150		1.5	1370	7870	1.29	7428	1.33	7018	1.38	78	\$4,035	\$3,764		
RB30T10100	360	1	965	9819	0.79	9022	0.87	7951	0.96	73	\$3,946	\$3,725	POD-34	\$140
RB30T10150		1.5	1005	11244	1.19	10548	1.28	9775	1.37	78	\$4,133	\$3,874		
RB30T10200		2	1220	12414	1.6	11783	1.7	11136	1.8	82	\$4,417	\$4,133		
RB36T10150	460	1.5	750	14271	1.24	12898	1.35	11091	1.41	75	\$4,328	\$4,082	POD-40	\$165
RB36T10200		2	835	15888	1.71	14661	1.84	13302	1.91	78	\$4,636	\$4,373		
RB36T10300		3	940	17886	2.44	16796	2.58	15636	2.69	83	\$5,062	\$4,515		
RB42T10150	520	1.5	620	17662	1.24	15897	1.31	---	---	75	\$4,466	\$4,245	POD-46	\$185
RB42T10200		2	685	19514	1.67	17906	1.73	16111	1.89	78	\$4,741	\$4,500		
RB42T10300		3	780	22220	2.47	20794	2.5	19341	2.68	83	\$5,160	\$4,658		
RB48T10200	680	2	565	23424	1.68	20606	1.82	---	---	77	\$4,635	\$4,426	POD-52	\$203
RB48T10300		3	640	26533	2.45	23933	2.59	21489	2.8	81	\$4,950	\$4,514		
RB48T10500		5	745	30886	3.86	28495	4	26703	4.24	86	\$5,243	\$4,616		
RB54T10300	880	3	530	30086	2.46	27332	2.58	24060	2.82	79	\$5,830	\$5,392	POD-58	\$234
RB54T10500		5	625	35472	4.03	33139	4.21	30532	4.41	84	\$6,270	\$5,646		
RB54T10750		7.5	720	40863	6.16	38809	6.44	36754	6.52	88	\$7,179	\$6,119		
RB60T10500	1050	5	520	42969	4.22	38510	4.5	34050	4.78	72	\$7,552	\$6,928	POD-67	\$270
RB60T10750		7.5	595	49167	6.32	45269	6.64	41372	6.96	87	\$8,225	\$7,167		
RB60T11000		10	650	53172	8.24	50144	8.59	46576	8.94	89	\$9,880	\$7,382		

INTERMEDIATE SIZES AVAILABLE

\*\*DIRECT DRIVE SERIES AVAILABLE - CONSULT THE FAN DEPT.

\* SHIPS LOOSE

## DIMENSIONS

Model #	A I.D.	B O.D.	C SQ.	D	E	F	G
RB24	25	31 1/2	29 1/2	3	4	19	18 1/2 max
RB30	31	36 1/2	35 1/2	3	4	22	18 1/2 max
RB36	37	43 1/2	41 1/2	3	4	25	18 1/2 max
RB42	43	49 1/2	47 1/2	3	4	27	18 1/2 max
RB48	49	55 1/2	53 1/2	3	4	30	18 1/2 max
RB54	55	61 1/2	59 1/2	3	4	36	21 max
RB60	61	70	68	2	5	42	21 max

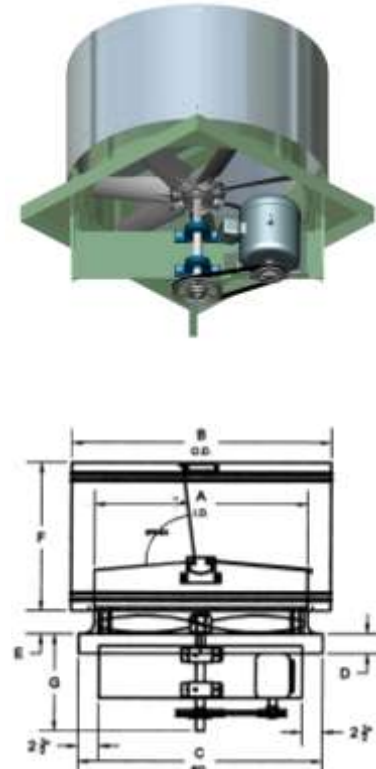



# ROOF FAN HOODED AXIAL EXHAUST - SUPPLY-REVERSABLE

- FEATURES**
- \*CAST ALUMINUM AIRFOIL PROPELLERS
  - \*TOTALLY ENCLOSED MOTORS
  - \*POLYESTER POWDER COATING EXCEPT GALVANIZED HOOD
  - \*REDUCED SOUND LEVEL
  - \*HINGED OR FIXED HOOD (FIELD OPTIONAL)
  - \*HOOD SHIPPED UN-MOUNTED
  - \*BIRD SCREEN INCLUDED
  - \*CURBS WITH DAMPER SHELF

(A) CURBS WITH DAMPER SHELF  
(B) MOTORIZED ON SUPPLY DUTY  
AND REVERSABLE

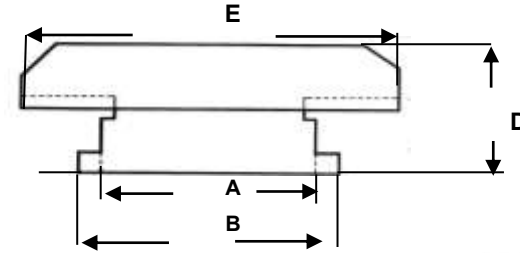

MODEL NO.	MTR HP	RPM	BHP	CFM @ SP				SOANS	3 PHASE 208-230-460	CURB 12" H		DAMPER / EXHAUST		MOTORIZED LIST**
				.125"	.25"	0.375	0.5			MODEL / LIST	SIZE / LIST	SIZE / LIST		
HHC-24-BD	1/2	1027	0.52	5217	4513	3231	2376	15	\$4,379	(A)				(B)
HHC-24-BD	3/4	1207	0.74	6059	5518	4856	3756	18	\$4,348	POD-35 opening	\$140	29 X 29	\$545	\$795
HHC-24-BD	1	1294	1.01	6866	6359	5794	5047	21	\$4,431					
HHC-24-BD	1 1/2	1481	1.49	7921	7446	6969	6439	25	\$4,790	29 X 29				
HHC-30-BD	3/4	878	0.75	8224	6933	5261	3461	17	\$4,730					
HHC-30-BD	1	929	1.00	9238	8189	6396	4845	20	\$4,826	POD-41 opening	\$165	35 X 35	\$570	846
HHC-30-BD	1 1/2	1064	1.51	10861	9969	8731	7240	23	\$5,172	35 X 35				
HHC-30-BD	2	1167	1.98	12072	11257	10464	8961	27	\$5,200					
HHC-36-BD	1 1/2	912	1.51	13743	12342	10554	8318	24	\$5,657	POD-47 opening	\$187	41 X 41	\$738	933
HHC-36-BD	2	970	2.01	15503	14225	12702	10902	27	\$5,716	41 X 41				
HHC-36-BD	3	1101	3.01	17896	16796	15619	14204	33	\$5,853					
HHC-42-BD	3	813	3.02	20756	19273	17661	15709	34	\$6,803	POD-54 48 X 48	\$211	48 X 48	\$1,123	974
HHC-42-BD	5	964	4.94	25129	23918	22597	21238	43	\$6,955					
HHC-48-BD	3	706	2.87	24556	22415	20191	17314	31	\$7,525	POD-59 opening	\$228	53 X 53	\$1,396	1,310
HHC-48-BD	5	849	4.98	30550	28846	27042	24918	39	\$7,649	53 X 53				
HHC-48-BD	7 1/2	967	7.35	35260	33810	32196	30289	46	\$8,330					
HHC-54-BD	5	753	4.88	35038	32760	29971	27235	47	\$8,637	POD-65 opening	\$252	59 X 59	\$1,721	1,440
HHC-54-BD	7 1/2	862	7.30	40689	38782	36713	34497	54	\$9,347	59 X 59				
HHC-54-BD	10	948	9.68	45109	43417	41565	39673	63	\$9,652					
HHC-60-BD	5	684	4.98	39566	36597	32905	29039	41	\$10,795	POD-71 opening	\$272	65 X 65	\$1,835	1,595
HHC-60-BD	7 1/2	783	7.42	46023	43569	40828	37829	48	\$11,623	65 X 65				
HHC-60-BD	10	860	9.79	50971	48816	45937	43395	49	\$12,013					
HHC-60-BD	15	986	14.70	58987	57181	55234	52548	55	\$13,050					

\*SPECIFY E (EXHAUST) S (SUPPLY) R (REVERSIBLE) TO MODEL # EXAMPLE EHH-24BD  
-INTERMEDIATE SIZES & SINGLE PHASE UNITS AVAILABLE CONSULT "THE FAN DEPT"  
-COROSION PROOF - EXPLOSION PROOF, AVAILABLE CONSULT "THE FAN DEPT"

FAN	A	B	D	E-LENGTH	F-WIDTH	WT LBS
24	30	36	34.5	60	34	300
30	36	42	37.5	72	40	340
36	42	48	40.5	82	46	430
42	48	54	43.5	92	52	500
48	54	60	45	102	58	575
54	60	66	45	108	64	800
60	66	72	51	120	70	875

# SUPPLY FAN AXIAL ROOF - WALL DMUA SERIES

**FEATURES:**

- \* SPUN ALUMINUM HOUSING
- \* 115 VOLT TOTALLY ENCLOSED MOTOR
- \* PROPELLERS CONSTRUCTED WITH DIE FORMED BLADES RIVETED TO A STEEL HUB
- \* CAN BE ROOF OR WALL MOUNTED
- \* STANDARD BIRD SCREEN
- \* WIRE CONDUIT
- \* EMERGENCY DISCONNECT SWITCH



MODEL	HP	RPM	CFM @ SP			EST LBS	FAN LIST	CURB		MOTOR DAMPER		WALL BRACKET
			1/8"	1/4"	3/8"			MODEL / LIST	MODEL / LIST	MODEL / LIST		
DMUA-14	1/6	1100	1174	904	670	45	\$563	POD-19.5	\$97	I-15	\$233	\$120
DMUA-18	1/3	1100	2220	1980	1639	67	\$700	POD-24.5	\$112	I-19	\$249	

MODEL	HT	W	B	C	D	E	RO	SHIP LBS	DAMPER SQ
DMUA 14	12 5/8	27 5/16	2	21	19 1/2	12	16	45	15
DMUA 18	14 3/8	33 9/16	2	26	24 1/2	12	20	67	19

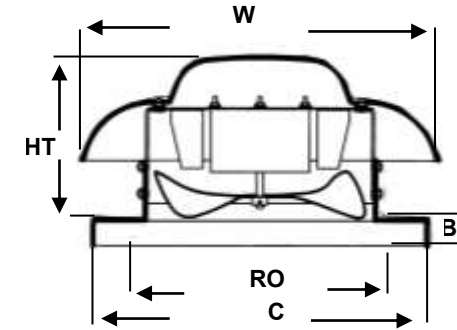

# FILTERED MAKE UP AIR (UNTEMPERED) - NSA SERIES

## FEATURES:

- \* HORIZONTAL OR DOWN DISCHARGE (SPECIFY WHEN ORDERING)
- \* GALVANIZED HOUSING
- \* COMPLETELY ASSEMBLED
- \* WIRED DISCONNECT
- \* QUICK LATCH COVER
- \* VIBRATION ISOLATION
- \* VARIABLE PITCH PULLEY
- \* 2" ALUMINUM MESH FILTERS
- \* LEAD TIME = 5 WORK DAYS



MODEL #	HP	MAX RPM	CFM @ SP					EST WT	1 PH 115/230	3PH 230/460	CURB 12"H MODEL / LIST	
			0	1/4	1/2	3/4	1					
NSA-10	1/2	837	2500	2000	---	---	---	175	\$990	\$1,015	POD-23	\$110
NSA-10	3/4	984	2500	2500	2000	2000	2000	180	\$1,020	\$1,024		
NSA-10	1	1000	2500	2500	2500	2500	2400	190	\$1,064	\$1,039		
NSA-12	1/2	722	3000	2500	2500	2000	---	275	\$1,278	\$1,303	POD-32.5	\$134
NSA-12	3/4	838	3500	3000	3000	2500	---	280	\$1,308	\$1,312		
NSA-12	1	856	3500	3500	3000	3000	2500	290	\$1,352	\$1,327		
NSA-12	1-1/2	883	4000	4000	4000	3500	3500	300	\$1,420	\$1,352		
NSA-12	2	993	4500	4500	4500	4000	4000	310	\$1,490	\$1,378		
NSA-15	3/4	543	4000	3500	3000	---	---	315	\$1,445	\$1,444	POD-32.5	\$134
NSA-15	1	623	4500	4000	3500	3500	---	325	\$1,493	\$1,460		
NSA-15	1-1/2	717	5000	5000	4500	4000	4000	335	\$1,550	\$1,488		
NSA-15	2	743	5500	5500	5000	4500	4500	345	\$1,621	\$1,515		
NSA-15	3	798	6000	6000	6000	5500	5500	350	\$2,050	\$1,749		

LARGER SIZES AVAILABLE - CONTACT "THE FAN DEPT"

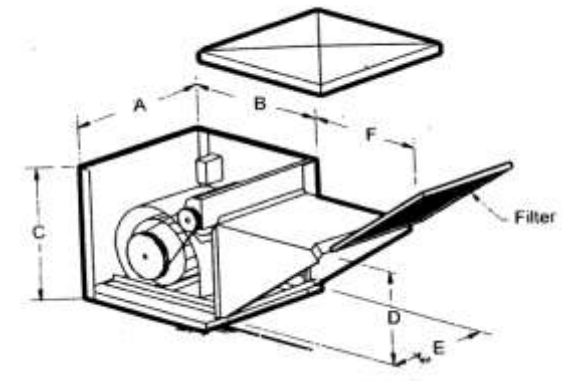

## MEASUREMENTS

MODEL	A	B	C	D	E	F	G	H	FILTER SIZE	WEIGHT
NSA 10	26	32	28	20	20	26	23	14	(2) 16"X20"	175
NSA 12	36	40	35	28 1/2	25	29	32 1/2	14	(2) 20"X25"	275
NSA 15	36	40	35	28 1/2	25	54	32 1/2	14	(3) 20"X25"	315

# ROOF CURB & ADAPTORS      POD SERIES

## CURBS

Model	Height	Use curbs with specific fan models below ↓	CURB LIST
POD-19.5	18"	BDU-11&13	\$145
POD-23.25	18"	BDU-15	\$164
POD-26.5	18"	BDU-18 &20	\$173
POD-31.5	18"	BDU-24	\$195
POD-38.5	18"	BDU-30	\$237
POD-43	18"	BDU-36	\$254
POD-17.5	12"	(DR10 ,12) (DDAR10-12)	\$87
POD-19.5	12"	(BDCR7-8-9-11-13) (DDAR14) ( DMUA14) (EMUA14) (DR25-,30-33-50)	\$97
POD-23	12"	(DDAR18) (DMUA18) (EMUA18) (BDCR-15)	\$109
POD-26.5	12"	(BDCR18-20)	\$115
POD-31.5	12"	(BDCR24)	\$131
POD-38.5	12"	(BDCR30)	\$158
POD-43	12"	(BDCR-36)	\$175
POD-47	12"	(HHC-36)	\$194
POD-54	12"	(HHC-42)	\$217
POD-59	12"	(HHC-48)	\$235



## ADAPTORS

Model #	Top OD	Bottom ID	Adaptor List Price
PCA	18.5 x	25	\$130
PCA	21.5 x	28	\$135
PCA	25.5 x	32	\$138
PCA	29.5 x	36	\$153
PCA	33.5 x	40	\$166
PCA	41.5 x	47	\$182
PCA	45.5 x	52	\$200

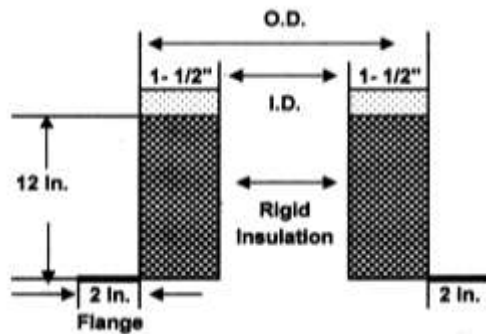

## ROOF CURB ADAPTORS

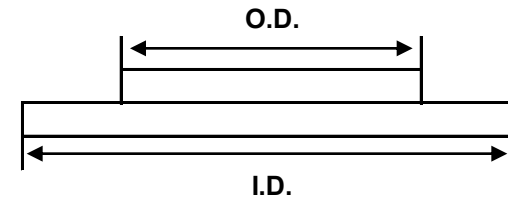

# FAN - SHUTTER- SWITCH COMBINATION CE-SERIES Light Duty

## FEATURES

- \* COMPLETELY ASSEMBLED WITH SWITCH
- \* BALL BEARING (SIZES 24 & 30)
- \* SLEEVE BEARING (SIZES 12 & 18)
- \* THREE SPEED - TWO SPEED
- \* 115V TOTALLY ENCLOSED MOTOR
- \* UL LISTED
- \* SWITCH INCLUDED (MOUNTED)
- \* AVAILABLE FROM MICHIGAN STOCK (NO RUSH FEE)



\*\*LEAD TIME = 3-5 DAYS

MODEL #	PROP SIZE	HP	C.F.M. @ 1/8" SP*			DIMENSIONS			WT LBS	LIST PRICE
			HI	MED	LOW	A	B	C		
CE10DS	10"	1/12	893	715	519	13.1	10.5	2.5	11	\$268
CE12DS	12"	1/12	1078	862	627	15.1	12.5	2.5	16	\$303
CE14DS	14"	1/8	1754	1430	976	17.1	14.5	2.5	17	\$384
CE16DS	16"	1/8	2003	1638	1113	19	16.5	2.5	18	\$402
CE18DS	18"	1/8	2254	1842	1254	21.1	18.5	2.5	25	\$436
CE20DS	20"	1/4	2293	---	1632	23.1	20.5	2.5	34	\$518
CE24DS	24"	1/4	2665	---	1960	27.1	24.5	2.5	47	\$577
CE30DS	30"	1/4	3096	---	2352	33.1	30.5	2.5	54	\$722

\* CFM BASED ON CALCULATIONS

\*\* FAN WITH VENTURI PANEL = SAME PRICE

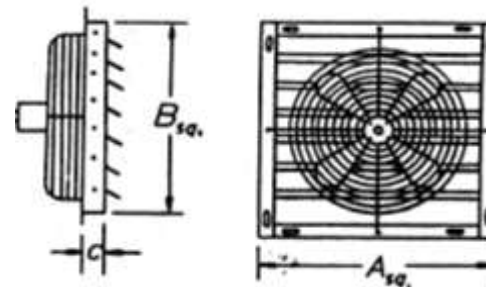



# FAN SHUTTER COMBINATION UNITS S-SERIES

## FEATURES

- \*COMPLETELY ASSEMBLED FAN AND SHUTTER
- \*OSHA APPROVED CHROME INTAKE GUARD
- \*115 VOLT AND 115/230V SINGLE PHASE MOTORS
- \*TOTALLY ENCLOSED, THERMALLY PROTECTED MOTORS
- \*WELDED FAN CABINET-POWER COATED FINISH
- \*ALUMINUM SHUTTER (8"-24") PVC SHUTTERS (30"-36")



MODEL #	BLADE DIA	HP	VOLTAGE	SPEED	RPM	AMPS	WEIGHT	CFM @ SP"				List Price
								0"	.10"	.125"	.25"	
S8-B2	8	1/40	115	2	1600/1300	0.5	12	360-300	270-150	230-110	0	\$250
S10-B2	10	1/40	115	2	1600/1300	0.5	13	690-580	590-460	570-390	0	\$262
S12-E1	12	1/4	115	1	1625	1.8	28	1640	1540	1510	1390	\$385
S12-EVD	12	1/3	115/230	VARIABLE	1700	5.0-2.5	32	1650	1540	510	1390	\$451
S14-E2	14	1/4	115	2	1725/1140	3.4	34	2180-1350	2080-1190	2060-1160	1890-0	\$487
S14-E1	14	1/3	115/230	1	1700	5.0-2.5	30	2170	2070	2030	1860	\$392
S16-E1	16	1/4	115	1	1625	1.8	33	2370	2270	2210	2060	\$409
S16-EVD	16	1/3	115/230	VARIABLE	1700	5.0-2.5	36	2370	2270	2210	2063	\$537
S18-F1	18	1/3	115	1	1625	4	37	3200	3090	3040	2920	\$424
S18-FVD	18	1/3	115/230	VARIABLE	1700	3.8-1.9	45	3150	3050	2980	2860	\$598
S20-F1	20	1/3	115	1	1625	4	41	3420	3220	3170	2920	\$487
S20-F2	20	1/3	115	2	1725/1140	5.3-2.9	45	3400-2300	3240-2000	3180-1950	2930-0	\$611
SD-24-F1	24	1/3	115	1	1100	5.4	56	5600	4500	4300	3600	\$613
SD-24-GVD	24	1/2	115/230	VARIABLE	1100	6.4-3.2	72	5050	4910	4810	4400	\$700
SD-30-G1D	30	1/2	115/230	1	1100	6.4-3.2	72	8000	7000	6000	5000	\$870
SD36-G1D	36	1/2	115/230	1	850	6.6-3.8	88	12000	11000	10500	9500	\$938

## EXPLOSION PROOF (CLASS 1-GROUP C&D / CLASS II GROUP F&G)

MODEL #	BLADE DIA	HP	VOLTAGE	SPEED	RPM	AMPS	WEIGHT	CFM @ SP"				List Price
								0"	.10"	.125"	.25"	
SD12-XPF	12	1/3	115/230	1	1625	6.6-3.3	42	1640	1600	1540	1390	\$1,043
SD18-XPF	18	1/3	115/230	1	1625	6.6-3.3	58	3200	3150	3090	2920	\$1,185
SD24-XPF	24	1/3	115/230	1	1625	6.6-3.3	85	5500	5400	5310	5100	\$1,258

### FAN DIMENSIONS

FAN SIZE	A X A SQUARE	B	C	D (c/c)	E	N
8"	13 1/4"	10"	4"	12"	10 3/4"	2
10"	15 1/4"	10"	4"	14"	12 3/4"	2
12"	17 1/4"	14"	6"	16"	14 3/4"	3
14"	19 1/4"	14"	6"	18"	16 3/4"	3
16"	21 1/4"	14"	6"	20"	18 3/4"	4
18"	23 1/4"	15"	6"	22"	20 3/4"	4
20"	25 1/4"	16"	6"	24"	22 3/4"	5
24"	29 1/4"	16"	6"	28"	26 3/4"	5
30"	35 1/4"	19"	6"	34"	32 3/4"	16
36"	41 1/4"	16"	8"	40"	38 3/4"	20

### EXPLOSION PROOF FAN DIMENSIONS

FAN SIZE	A X A SQUARE	B	C	D (c/c)	E	N
12"	17 1/4"	20 1/2"	6"	16"	14 3/4"	3
18"	23 1/4"	20 1/2"	6"	22"	20 3/4"	4
24"	29 1/4"	20 1/2"	6"	28"	26 3/4"	5

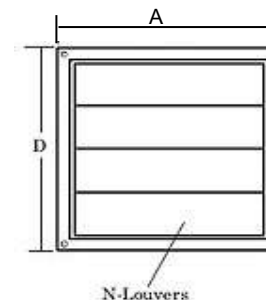
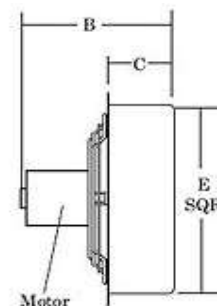

# STANDARD DUTY BELT DRIVE EXHAUST OR SUPPLY -- VI SERIES

## FEATURES:

- \* INCLUDES WALL HOUSING & REAR GUARD
- \* SUPPLY OR EXHAUST 24" - 42"\*(PLEASE SPECIFY)
- \* VERY QUIET-LOW RPM
- \* BELT TENSION SPRING (24"-48" MODELS UP TO 1-1/2HP)
- \* RAIN HOODS AND SHUTTERS PRICED SEPARATELY
- \* LEAD TIME 3-10 WORK DAYS

\* 115/230 FANS ARE WIRED FOR 115V\*\*

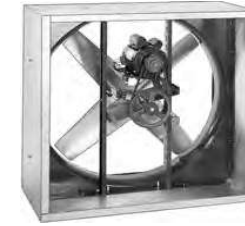

MODEL	HP	RPM	SHIP WT	CFM @ SP			ODP		EXPLOSION PROOF		RAINFOOD W/BIRDSCREEN		SHUTTER	
				0	1/8	1/4	1 PHASE	3 PHASE	1 PHASE	3 PHASE	MODEL / LIST		MODEL / LIST	
							115/230	208/230/460	115/230	208/230/460				
VI-2412	1/3	705	101	4100	3717	2952	\$ 872	\$1,093	\$2,148	\$2,289	RH-24	\$269	IWS-24	\$161
VI-3013	1/2	742	113	9000	7400	4050	\$ 1,061	\$1,176	\$2,351	\$2,423	RH-30	\$338	IWS-30	\$197
VI-3014	3/4	732	117	10000	9200	7600	\$ 1,057	\$1,187	\$2,574	\$2,621				
VI-3613	1/2	550	138	10400	8875	5824	\$ 1,156	\$1,196	\$2,446	\$2,491				
3614	3/4	540	146	11100	10027	7881	\$ 1,158	\$1,274	\$2,675	\$2,723	RH-36	\$419	IWS-33	\$263
3615	1	555	164	12100	11172	9317	\$ 1,356	\$1,472	\$3,098	\$3,523				
VI-4214	3/4	565	153	14600	12507	8322	\$ 1,283	\$1,399	\$2,800	\$2,847				
4215	1	475	164	15900	13939	10017	\$ 1,447	\$1,563	\$3,189	\$3,614	RH-42	\$528	IWS-39	\$343
4216	1-1/2	450	161	17100	15675	12825	\$ 1,980	\$1,616	---	\$3,840				
VI4814 *	3/4	455	187	18900	17766	15498	\$ 1,421	\$1,485	\$2,938	\$2,934				
4815	1	470	198	20500	17561	11685	\$ 1,594	\$1,649	\$3,336	\$3,700				
4816	1-1/2	480	200	20800	18235	13104	\$ 2,210	\$1,922	---	\$4,146	RH-48	\$640	IWS-45	\$396
4817	2	605	267	21100	19341	15825	\$ 2,992	\$2,336	---	\$4,849				
4818	3	610	291	23700	22278	19434	\$ 3,434	\$2,754	---	\$5,599				
VI-5417	2	615	338	25500	22355	16065	\$ 4,875	\$4,219	---	\$6,732				
5418	3	620	343	30100	27592	22575	\$ 5,152	\$4,471	---	\$7,317	RH-54	\$788	IWS-54	\$766
5419	5	650	343	37200	34968	30504	---	\$4,724	---	\$7,994				
VI-6017	2	611	410	30200	26476	19026	\$ 5,643	\$4,987	---	\$7,500				
6018	3	610	418	34000	31167	25500	\$ 5,896	\$5,215	---	\$8,060	RH-60	\$986	IWS-60	\$848
6019	5	650	422	43100	40514	35342	---	\$5,405	---	\$8,675				

## DIMENSIONS

FAN	OVERALL (IN)	DEPTH	WALL OPENING
VI-24	30-3/4 X 30-3/4	20	31 X 31
VI-30	34-3/4 X 34-3/4	20	35 X 35
VI-36	40-3/4 X 40-3/4	20	41 X 41
VI-42	46-3/4 X 46-3/4	20	47 X 47
VI-48 (1-1/2HP)	52-3/4 X 52-3/4	20	53 X 53
VI-48 (2HP)	52-3/4 X 52-3/4	24	53 X 53
VI-48 (3HP)	52-3/4 X 52-3/4	30	53 X 53
VI-54	62-7/8 X 62-7/8	30	63-1/4 X 63-1/4
VI-60	68-7/8 X 68-7/8	30	69-1/4 X 69-1/4

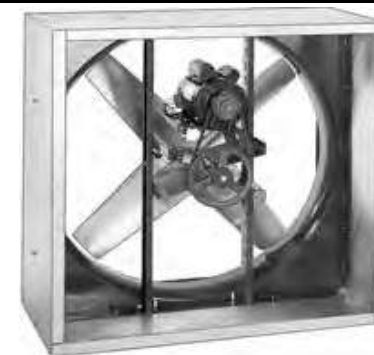

# WALL FAN EXHAUST/SUPPLY\* HEAVY DUTY BELT DRIVE SERIES HV

**FEATURE:**

- \*EXHAUST OR SUPPLY
- \*HEAVY DUTY WELDED CONSTRUCTION
- \*GALVANIZED BLADES STATICALLY & DYNAMICALLY BALANCED

\*TOTALLY ENCLOSED MOTORS

\*COMPLETE ACCESSORIES

\*LEAD TIME "10" WORK DAYS

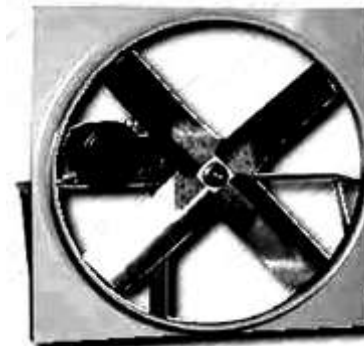

MODEL#	HP	FAN RPM	CFM @ SP				DBA @ 5	"FAN ONLY" LIST			**PACKAGE LIST		Rain Hood
			.125"	0.25"	.50"	0.75"		AVG WT.	1 PH TE 115/230V*	3 PH TE 230/460V*	1 PH	3 PH	
HV24-1	1	1175	6234	5797	3748	2544	74	151	\$1,934	\$1,824	\$2,591	\$2,480	GH-
HV24-1.5	1.5	1375	7458	7049	5824	4049	78	156	\$1,953	\$1,933	\$2,609	\$2,590	KD24
HV24-2	2	1575	8303	7906	7051	5310	81	160	\$2,159	\$2,045	\$2,815	\$2,702	\$285
HV30-1	1	890	8192	6801	3715	1739	73	168	\$2,146	\$2,036	\$2,968	\$2,856	GH-
HV30-2	2	1230	11890	11253	9087	6499	82	179	\$2,347	\$2,234	\$3,167	\$3,055	KD36
HV30-3	3	1405	13749	13201	11823	9334	84	190	\$2,835	\$2,324	\$3,657	\$3,145	\$285
HV36-2	2	790	13734	12277	7757	4174	77	249	\$2,667	\$2,477	\$3,649	\$3,537	GH-
HV36-3	3	935	16695	15526	11533	8689	82	260	\$3,050	\$2,539	\$4,111	\$3,599	KD36
HV36-5	5	1140	20793	19893	17883	13983	88	281	\$3,298	\$2,728	\$4,367	\$3,788	\$408
HV42-3	3	785	20945	19507	15061	9620	82	323	\$3,349	\$2,838	\$4,628	\$4,117	GH-
HV42-5	5	935	25434	24286	21550	17023	87	348	\$3,696	\$3,050	\$5,013	\$4,335	KD48
HV42-7.5	7.5	1085	29873	28861	26753	24157	91	373	\$4,843	\$3,742	\$6,215	\$5,058	\$408
HV48-3	3	635	23713	21228	12756	8491	80	363	\$4,099	\$3,587	\$5,495	\$4,981	GH-
HV48-5	5	750	28711	26930	21753	14025	85	383	\$4,287	\$3,800	\$5,682	\$5,196	KD48
HV48-7.5	7.5	875	34042	32521	28814	23883	89	413	\$5,088	\$4,175	\$6,539	\$5,637	\$804
HV48-10	10.0	940	36891	35374	32194	27942	92	433	\$6,702	\$6,177	\$8,336	\$7,629	
HV54-5	5	620	32838	30203	21951	14820	83	453	\$4,872	\$4,386	\$6,649	\$6,158	GH-
HV54-7.5	7.5	720	38809	36754	31736	21541	88	473	\$5,752	\$4,840	\$7,758	\$6,667	KD60
HV54-10	10	800	43529	41789	37594	31683	91	493	\$7,353	\$5,008	\$9,503	\$6,837	\$968
HV60-5	5	510	37596	32867	19643	13537	81	513	\$5,802	\$5,317	\$8,442	\$7,837	GH-
HV60-7.5	7.5	600	45715	41850	29660	21797	86	533	\$7,142	\$6,229	\$9,720	\$8,806	KD60
HV60-10	10	670	51903	48442	38454	28617	89	553	\$8,539	\$6,435	\$11,385	\$9,013	\$968

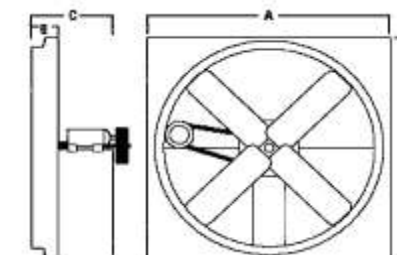

MODEL	BLADE DIAMETER	A	B	C
HV24	24"	29 5/8"	6 5/8"	15 1/2"
HV30	30"	35 5/8"	6 3/4"	16"
HV36	36"	41 5/8"	7 1/4"	16 1/2"
HV42	42"	47 5/8"	7 3/4"	17"
HV48	48"	53 5/8"	7 3/4"	17"
HV54	54"	59 3/4"	8"	21" +
HV60	60"	68"	7 3/4"	21 3/4" +

\*\*PACKAGE INCLUDES: FAN, HOUSING, REAR GUARD, SHUTTER

\*SUPPLY DUTY - ADD 10% TO FAN. SUPPLY DUTY SHUTTER SEE PAGE 40  
 INTERMEDIATE SIZES AVAILABLE - CONSULT "THE FAN DEPT"

# EXHAUST WALL FAN - DIRECT DRIVE - MEDIUM DUTY DDS SERIES

**FEATURE:**

- \* DEEP SPUN VENTURI
- \* DIRECT DRIVE SIMPLICITY
- \* WELDED CONSTRUCTION
- \* GALVANIZED STEEL BLADE
- \* TEFC MOTOR
- \* COMPLETE ACCESSORIES
- \* LEAD TIME "10" WORK DAYS



MODEL#	HP	FAN RPM	CFM @ SP					DBA @ 5	AVG WT.	LIST PRICES		PACKAGED LIST		RAINHOOD	
			.125"	0.25"	.375"	.50"	.675"			1 PH TE 115/230V*	3 PH TE 230/460V*	1PH	3PH	MODEL / LIST	
DDS12T-33 C	1/3	1140	647	325	----	----	----	53	15	\$1,182	\$879	\$1,487	\$1,193	EH-12	\$348
DDS12T-33 B	1/3	1750	1285	1062	697	587	419	65	15	\$762	\$720	976	\$1,077		
DDS14T-33 C	1/3	1140	1082	624	395	111	----	58	20	\$1,193	\$891	\$1,543	\$1,226	EH-14	\$362
DDS14T-33 B	1/3	1750	1879	1705	1417	1032	882	67	20	\$797	\$754	1033	\$1,136		
DDS18T-50 B	1/2	1750	3816	3594	3304	2934	2173	74	30	\$813	\$785	\$1,218	\$1,207	EH-18	\$392
DDS20T-1 B	1	1750	5162	4926	4674	4350	3951	78	35	\$1,080	\$971	\$1,449	\$1,539	EH-20	\$415
DDS24T-75 C	3/4	1140	6017	5527	4482	3454	2801	73	37	\$1,928	\$1,821	\$2,531	\$2,463	EH-24	\$551
DDS24T-10 B	1	1750	6453	6128	5792	5291	4802	81	37	\$1,394	\$1,285	1889	\$1,927		
DDS24T-30 B	3	1750	9558	9207	8886	8599	8131	84	37	\$2,192	\$1,688	2641	\$2,330		
DDS30T-1.5 C	1 1/2	1140	10925	10193	9127	7504	6177	79	44	---	\$1,896	---	\$2,699	EH-30	\$614
DDS30T-5 B	5	1750	17106	16661	16215	15745	15190	90	47	\$2,475	\$1,999	3178	\$2,803		
DDS36T-2 D	2	860	15172	13864	11597	9443	8094	80	51	----	\$4,863	---	\$5,902	EH-36	\$730
DDS36T-5 C	5	1140	20793	12893	18903	17883	15993	88	51	----	\$2,828	---	\$2,832		
DDS42T-5 D	5	860	23193	21957	20490	18660	15890	85	60	----	\$6,221	---	\$7,527	EH-42	\$1,047
DDS42T-5 C	5	1140	22619	21962	21019	19925	18829	88	60	----	\$3,175	---	\$4,411		
DDS48T-7.5 D	7.5	860	33411	31857	30219	28021	25622	89	75	----	GET QUOTE	---		EH-48	GET QUOTE
DDS48T-7.5 C	7.5	1140	31677	30688	29636	28562	27222	92	75	----	GET QUOTE	---			

FAN SIZE	A	B	C
12"	16 1/4"	2 1/2"	9 1/2"
14"	18 1/4"	2 3/4"	9 3/4"
18"	22 1/4"	3 1/2"	10 1/2"
20"	24 1/4"	3 3/4"	10 3/4"
24"	29 5/8"	6 5/8"	13 1/2"
30"	35 5/8"	6 3/4"	13 3/4"
36"	41 5/8"	7 1/4"	14"
42"	47 5/8"	7 3/4"	14 3/4"
48"	53 5/8"	7 3/4"	17 3/4"

INTERMEDIATE SIZES AVAILABLE - CONSULT "THE FAN DEPT"  
 SUPPLY DUTY AVAILABLE - CONSULT "THE FAN DEPT"  
 PACKAGED UNITS INCLUDE, FAN, HOUSING, REAR GUARD, SHUTTER

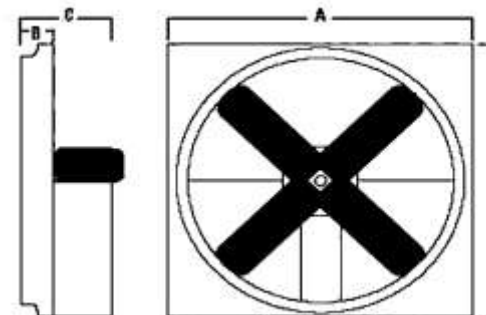

# CEILING CABINET FANS

## FEATURES

- \* INLINE OR CEILING APPLICATION
- \* HORIZONTAL/VERTICAL DISCHARGE
- \* 120V OPERATION
- \* INCLUDES GRILL AND BD DAMPER
- \* STEEL INSULATED HOUSING
- \* INCLUDES DISCONNECT PLUG
- \* AVAILABILITY - 2 DAYS



MODEL #	DUCT SIZE	SONES 1/8"SP	WATTS	CFM @ S.P.					WT LBS	LIST \$	INLINE #	KIT \$	WALL CAP		ROOF CAP		SPD CTRL	
				0	0.1	0.125	0.25	0.375					#	\$	#	\$	#	\$
#670	3"DIA	N/A	N/A	56	51	50	--	--	4	\$52	N/A	---	642	\$66	636P	\$25	N/A	---
#684	4"DIA	N/A	N/A	89	87	80	--	--	7	\$100	N/A	---					N/A	---
CFA100FA	6" DIA	0.9	88	136	115	109	93	80	23	\$182	961L	\$31	641	\$74	634M	\$63	3AMP	\$42
CFA150FA	6" DIA	1.5	96	181	161	157	141	132	23	\$194								
CFA200FA	8" DIA	1.7	124	231	214	210	196	186	23	\$237								
CFA250FA	8" DIA	2.2	160	272	261	259	250	242	23	\$250	981L	\$31	643	\$100	634	\$44	3AMP	\$42
CFA300FA	8" DIA	2.7	204	312	309	308	303	296	24	\$258								
CFA400FA	4 1/2 X 18	2.3	137	480	442	434	388	344	34	\$401	982L	\$44	643	\$100	437	\$190	3AMP	\$42
CFA500FA	4 1/2 X 18	3.3	207	538	520	514	491	463	34	\$450								
CFA700FA	4 1/2 X 18	4.7	298	722	704	701	667	640	34	\$487	982L	\$44	613	\$108	437	\$190	3AMP	\$42
CFA900FA	8 X 12	4.1	261	918	905	901	877	842	65	\$571								
CFA1500FA	8 X 12	8.4	436	1578	1526	1513	1438	1371	65	\$697	983L	\$48	613	\$108	612	\$170	6AMP	\$89

## DIMENSIONAL DATA

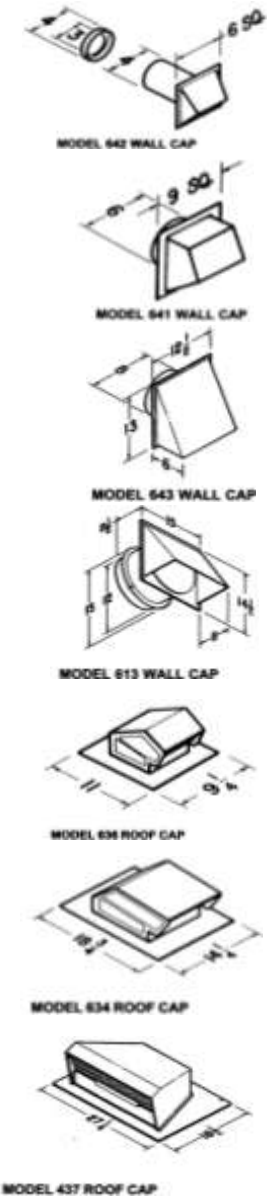
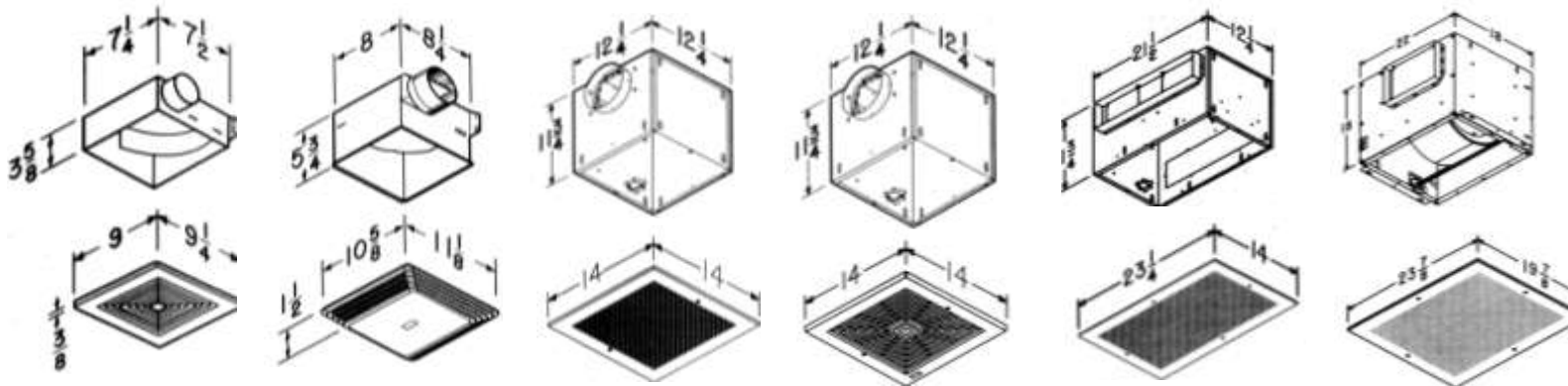

# INLINE CENTRIFUGAL BLOWERS\*\*----- CK SERIES

## FEATURES:

- VIBRATION FREE - QUIET OPERATION
- 120V VARIABLE SPEED MOTORS
- POWER CORD
- RUST PROOF EPOXY COATING
- STEEL HOUSING WITH MOUNTING BRACKET
- SUITABLE FOR 140° F AIR STREAM
- AVAILABLE FROM MICHIGAN STOCK  
(ALL OTHERS FROM TORONTO CANADA)

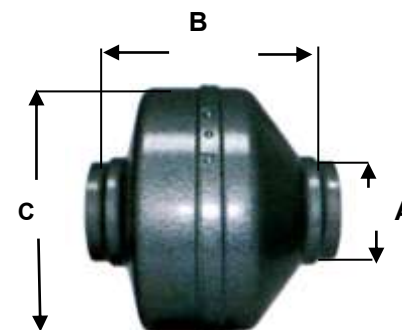

MODEL #	MAX WATTS	MAX AMPS	RPM	DUCT DIA	CFM @ SP							LIST PRICE
					1/8	1/4	3/8	1/2	3/4	1	1-1/4	
CK4A	44	.38	1800	4"	90	75	55	45	40	30	-	\$199
➔ CK4C	77	.69	2500	4"	160	140	130	120	100	70	45	\$212
CK5A	44	0.39	1800	5"	140	90	75	60	45	-	-	\$218
CK5C	78	0.70	2500	5"	230	205	170	145	105	80	50	\$222
➔ CK6B	77	0.70	2500	6"	250	220	200	180	130	100	65	\$223
➔ CK6C	135	1.19	2500	6"	580	560	460	430	300	200	70	\$297
➔ CK8A	144	1.26	2500	8"	575	545	510	450	360	230	200	\$298
CK8B	210	1.85	2500	8"	640	610	560	510	430	360	260	\$348
CK10A	142	1.24	2500	10"	590	565	510	450	375	275	235	\$361
➔ CK10C	228	2.00	2500	10"	680	650	630	600	520	430	350	\$399
CK12B	229	2.2	2500	12"	880	825	810	790	690	485	400	\$486
➔ CK12C	301	2.65	2500	12"	980	930	880	850	780	660	530	\$548

➔ STOCKED FANS SHIPPED SAME DAY BY FEDEX

## ACCESSORIES

### CONTROLS (LINE VOLTAGE)

CONTROLS		MODEL	LIST PRICE
SPEED CONTROL	3 AMP	VESC-3	\$44
TIMER (MINUTES)	0-6	CTI	40
PRESSURE SWITCH	115 V	PS-115V	
THERMOSTAT	115 V	TPI	30
DEHUMIDISTAT	115 V	DH115V	40

### BACKDRAFT DAMPERS--GRILLES

DUCT SIZE	DAMPER MODEL	LIST	GRILLE MODEL	LIST
4"	RSK-4	\$22	GR-4	\$18
5	RSK-5	27	GR-5	20
6	RSK-6	30	GR-6	21
8	RSK-8	44	GR-8	28
10	RSK-10	52	-	-
12	RSK-12	74	-	-

CK SERIES DIMENSIONAL DATA			
MODEL	A"	B"	C"
CK-4 A-B	3.94	7.40	9.60
CK-5 A-C	4.94	7.30	9.60
CK-6 B	5.90	7.70	10.70
CK-6 C	5.90	9.00	13.60
CK-8 A-B	7.90	9.00	13.60
CK-10 A-C	9.80	9.00	13.60
CK-12 B-C	11.80	10.20	15.90

\*\* OSTBERG FAN CO. AVESTA, SWEDEN

# DIRECT DRIVE SQUARE INLINE - SIDD SERIES

## FEATURES:

- \* BACKWARD INCLINED WHEELS
- \* ALUMINUM WHEEL
- \* GALVANIZED STEEL HOUSING
- \* SPEED CONTROL & DISCONNECTS STANDARD
- \* 2 ACCESS PANELS
- \* FILTER BOXES AVAILABLE

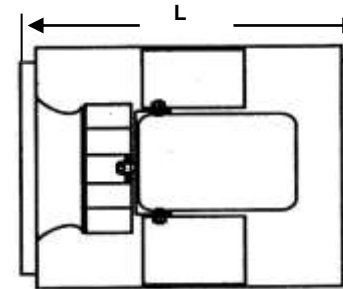

LEAD TIME = 7-10 WORK DAYS

MODEL	RPM	HP	CFM @ S.P.				SHIP LBS	LIST PRICE
			1/4	1/2	3/4	1		
SIDD-080	1650	1/8	545	459	335	---	100	\$860
SIDD-090	1650	1/8	843	729	578	---	103	\$860
SIDD-100	1750	1/3	1484	1365	1236	1083	108	\$944
SIDD-120	1750	3/4	2041	1942	1834	1709	130	\$1,182
SIDD-135	1750	3/4	2024	1922	1808	1685	135	\$1,306
SIDD-150	1160	1/2	2409	2213	1965	1514	160	\$1,437
SIDD-165	1160	1	3592	3327	3044	2640	170	\$1,628

DAMPERS		LIST PRICE
080	I-12	\$50
090	I-12	\$50
100	I-12	\$50
120	I-12	\$50
135	I-15	\$64
150	I-15	\$64
165	I-19	\$80

DIMENSIONS (IN)			DUCT FLANGE
MODEL	LENGTH	H & W	
10	20-1/16	16 1/6	14 X 14
12	20-1/16	20-1/16	17 X 17
13	22-1/16	22-1/16	18-3/4 X 18-3/4
15	24-9/16	24-9/16	20-7/8 X 20-7/8

ACCESSORIES	LIST
VIBRATION ISOLATORS - RUBBER	\$121
VIBRATION ISOLATORS - FLOOR	\$631

# BELT DRIVE SQUARE INLINE - SIBD SERIES

## FEATURES:

- \* HIGH VOLUME BACKWARD INCLINED WHEEL
- \* VERTICAL OR HORIZONTAL MOUNT
- \* JUNCTION BOX PROVIDED
- \* LEAK PROOF SIDE PANEL ACCESS
- \* ANGLE IRON MOUNTING LUGS
- \* 3-7.5HP MOTORS UNMOUNTED (ELIMINATE DAMAGE)
- \* LEAD TIME 5-15 WORK DAYS



MODEL	RPM	HP	CFM @ SP				WT LBS	1 PHASE 115/230	3 PHASE 230/460
			1/4"	1/2"	3/4"	1"			
SIBD-100	1846	1/3	1417	1308	1184	1038	109	\$1,434	----
	2126	1/2	1654	1563	1463	1353	111	\$1,456	\$1,432
	2554	3/4	1906	1829	1746	1656	113	\$1,493	\$1,443
SIBD-120	1704	1/2	1867	1751	1631	1476	124	\$1,519	\$1,493
	1938	3/4	2166	2067	1965	1858	126	\$1,552	\$1,502
	2176	1	2393	2304	2211	2118	126	\$1,602	\$1,519
SIBD-150	1414	3/4	2792	2620	2440	2209	152	\$1,739	\$1,690
	1541	1	3096	2940	2781	2607	152	\$1,789	\$1,706
	1713	1-1/2	3592	3458	3320	3181	159	\$1,848	\$1,735
SIBD-180	1148	1	4135	3922	3640	3252	203	\$2,017	\$1,935
	1331	1-1/2	4803	4611	4394	4137	210	\$2,076	\$1,963
	1423	2	5322	5153	4967	4757	219	\$2,144	\$1,992
SIBD-210	1137	1-1/2	5516	5254	4949	4570	237	\$2,170	\$2,057
	1175	2	6091	5860	5601	5299	246	\$2,238	\$2,085
	1347	3	7031	6863	6626	6395	302	\$2,616	\$2,163
SIBD-245	902	2	8136	7642	7059	6345	328	\$2,840	\$2,688
	1039	3	9437	9025	8566	8042	384	\$3,218	\$2,765
	1236	5	11334	11000	10644	10259	402	----	\$2,979
	1256	7-1/2	13047	12762	12462	12147	460	----	\$3,173

LARGER SIZES AVAILABLE - CONSULT THE FAN DEPT

SIZE	MTR COVER	FLOOR MT SPRING ISO	RUBBER ISO
100	BSIMC120 \$77	5C126-4 631	8860041-4 109
120	BSIMC120 \$77	5C126-4 631	8860041-4 109
150	BSIMC135 \$77	SLFA125-4 397	8860041-4 109
180	BSIMC180 \$77	SLFA125-4 397	8860042-4 121
210	BSIMC180 \$77	SLFA125-4 397	8860042-4 121
245	BSIMC225 \$104	SLFA200-4 397	8860043-4 121

SIZE	DIMENSIONS		MOTOR COVER	
	A H,W,L	B FLANGE SQ	D	E
10	16.1 (L=20.1)	14	13-1/4	14-1/4
12	20.1 CUBED	17	13-1/5	14-1/4
15	24.6 CUBED	20-7/8	13-1/6	14-1/4
18	28.7 CUBED	25-3/8	16-3/4	16-3/4
20	31.4 CUBED	27-3/4	16-3/4	16-3/4
24	37.6 CUBED	34	21-3/4	21-3/4

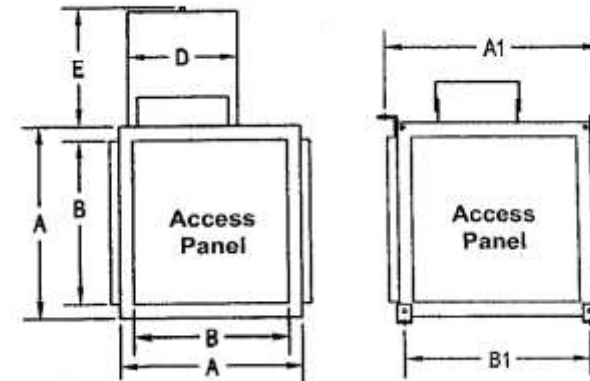



# DUCT BLOWER - D200 SERIES

## FEATURES:

- \* QUIET BELT DRIVE
- \* VERTICAL OR HORIZONTAL MOUNT
- \* ADJUSTABLE MOTOR PULLEY
- \* FORWARD CURVE WHEEL
- \* OPTIONAL FILTER SECTION
- \* OPTIONAL INSULATED CABINET



MODEL	HP	RPM	CFM @ SP					W	LIST PRICES		FILTER SECTION
			1/8	1/4	1/2	3/4	1		ODP 1 PH	3 PH	
D 207	1/4	1451	1100	1000	900	800	75	\$725	\$850		
D 207	1/3	1473	1200	1100	1000	900	75	\$737	\$864		
D 207	1/2	1588	1400	1300	1200	1100	75	\$750	\$882		
D 209	1/4	1128	1400	1300	1200	1000	75	\$756	\$882		
D 209	1/3	1112	1600	1500	1400	1200	100	\$786	\$764	\$186	
D 209	1/2	1132	1700	1700	1700	1500	140	\$850	\$914		
D 212	1/3	904	2300	2200	2000	1800	1200	\$932	\$928		
D 212	1/2	905	2800	2700	2500	2000	1600	\$1,014	\$1,077	\$244	
D 212	3/4	906	3000	2900	2800	2600	2400	\$1,112	\$1,086		
D 212	1	907	3400	3400	3200	3000	2800	\$1,204	\$1,154		
D 215	3/4	725	3700	3600	3200	2800	2300	\$1,377	\$1,351		
D 215	1	751	4000	3900	2600	3300	2900	\$1,468	\$1,418	\$284	
D 215	1-1/2	786	4400	4400	4400	4100	3800	\$1,667	\$1,515		
D 218	1	615	5600	5400	4800	4000	3000	\$2,333	\$2,283		
D 218	2	627	7200	7000	6600	6000	5400	\$2,794	\$2,421	\$412	
D 218	3	660	7600	7600	7600	7400	6800	\$2,813	\$2,275		

CALL FOR SPECIAL PRICING

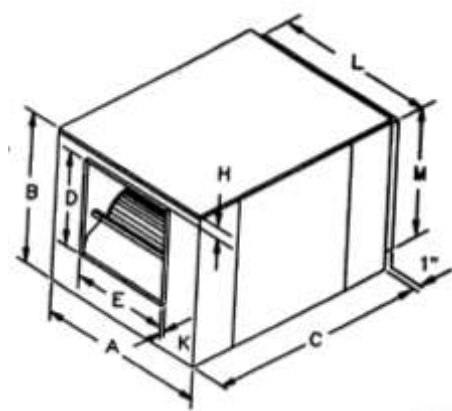

LEAD TIME = 3-6 WORK DAYS

EXTENDED SP RATINGS AND HP'S AVAILABLE - \*CONTACT THE FAN DEPT.

DIMENSIONS (inches)								
MODEL	A	B	C	D	E	F	L	M
207	18	15-3/8	23	8-1/4	9-3/16	14-1/2	15-7/8	13-3/8
209	21	18	23	10-1/4	11-13/16	17-1/2	19	16
210	22-1/4	20	24-3/4	11-3/8	13-1/8	18-3/4	20-1/4	18
212	27	23	27-1/2	13-7/16	15-5/8	23-1/2	25	21
215	33-1/2	28	32	15-7/8	18-5/8	28	30-1/2	25
218	41-1/2	34	44	19-5/8	22-5/8	35	35-3/8	31-5/8

# HEAVY DUTY DUCT BLOWER - 9200 SERIES

## FEATURES:

- \* OPTIONAL HOT WATER/STEAM/DX COIL
- \* VERTICAL AND HORIZONTAL APPLICATION
- \* MOUNTS INDOORS OR OUTDOORS
- \* INSULATED CABINET
- \* QUIET FORWARD CURVE WHEEL
- \* BALL BEARINGS SUITABLE FOR -65 TO +250 F
- \* LEAD TIME 5-15 WORK DAYS

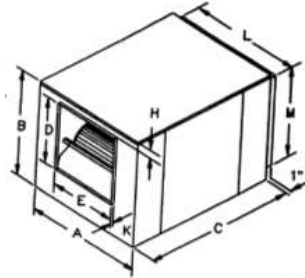

MODEL	HP	RPM	CFM @ SP						1 PH	3 PH	FILTER SECTION	FILTER HOOD	HOT-H2O COIL	COLD-H2O COIL
			1/2	3/4	1	1-1/2	2	2-1/2						
9212	1/2	902	2250	2000	1500	1000	--	--	\$1,748					
	3/4	1104	2750	2500	2250	1750	--	--	\$1,757					
	1	968	3000	2750	2250	1500	--	--	\$1,825	\$54	\$50	\$586	\$970	
	1-1/2	1426	3750	3500	3000	2500	2000	--	\$2,074	\$21				
	2	1429	4250	4000	3500	3000	2750	--	\$2,384	\$199				
9215	1	940	4000	3250	2750	2000	900	--	\$2,128					
	1-1/2	1067	4750	4250	3750	3000	2250	50	\$2,377	\$284	\$400	\$791	\$1,443	
	2	1100	5250	5000	4500	4000	3500	2400	\$2,639	\$284	\$400	\$791	\$1,443	
	3	1137	6000	6000	5750	5000	4000	3750	\$2,799	\$284	\$400	\$791	\$1,443	
9218	1-1/2	750	5000	5000	4500	3000	--	--	\$3,227	\$3,075				
	2	800	6000	6000	5500	4000	2500	--	\$3,490	\$3,116	\$412	\$471	N/A	N/A
	3	850	7500	7000	6500	5500	4500	3500	\$3,649	\$3,111	\$412	\$471	N/A	N/A
	5	975	8000	8000	8000	8000	7000	6000	\$3,841	\$3,374	\$412	\$471	N/A	N/A
9220	3	673	8500	8000	7000	6000	--	--	\$6,252	\$5,714				
	5	844	10500	10000	9500	8500	7000	6000	\$6,444	\$5,977	\$954	\$413	N/A	N/A
	7-1/2	880	12000	12000	11500	10500	9500	8500	\$7,470	\$6,635	\$954	\$413	N/A	N/A
	10	921	13500	13500	13000	12000	11500	10500	\$7,844	\$6,920	\$954	\$413	N/A	N/A

LARGER AND INTERMEDIATE SIZES AVAILABLE - CONSULT THE FAN DEPT.

MODEL	A	B	C	D	E	H	K	L	M	WT. (LBS)
9209	21	18	23	11-1/4	12-3/4	1	1-1/8	19	16	64
9210	22-1/4	20	24-3/4	12-3/8	14-1/8	1	1-1/8	20-1/4	18	74
9212	30-1/8	24-3/4	34	14-1/2	16-5/8	2-1/8	1-1/8	25-1/8	21-1/8	175
9215	33-3/4	28-5/8	38-1/8	17	19-5/8	2-1/8	1-1/8	30-5/8	25-1/4	214
9218	41-1/2	34	44	19-5/8	22-5/8	2-3/4	1-1/8	35-3/8	31-5/8	370
9220	44-3/4	41-1/8	57-1/2	25-3/4	25-3/4	3	1-1/8	38-3/8	35-1/8	575

# BELT DRIVE TUBE AXIAL FAN

- Features:**
- \*NON-SPARKING CAST ALUMINUM PROPELLERS
  - \*BELTS, SHEAVES AND BEARINGS PROTECTED FROM AIR STREAM
  - \*SEALED BALL BEARINGS WITH EXTERNAL GREASE FITTINGS
  - \*BALL BEARING INDUSTRIAL MOTORS

- \* HEAVY GAUGE STEEL DRUM
- \* HI TEMPERATURE MODELS AVAILABLE - CONSULT "THE FAN DEPT"
- \* SPRAY PROOF MODELS AVAILABLE - CONSULT "THE FAN DEPT"
- \* LEAD TIME 10-15 WORK DAYS

MODEL NUMBER	HP	FAN SIZE	FAN RPM	CFM @ SP					T.E.F.C		EXPLOSION PROOF	
				1/8"	1/4"	1/2"	3/4"	1"	1 PH	3 PH	1 PH	3 PH
				115/230v	230/460V	115/230V	230/460V					
TAB12-1/3	1/3	12"	2875	1436	1350	415	--	--	\$1,486	\$1,442	\$1,971	\$1,902
TAB12-1/2	1/2	12"	3450	1650	1400	1250	1100	660	\$1,427	\$1,520	\$1,810	\$1,881
TAB12-3/4	3/4	12"	3450	1960	1920	1650	1500	1100	\$1,572	\$1,575	\$1,979	\$2,040
TAB15-1/3	1/3	15"	2200	2500	2100	1000	--	--	\$1,597	\$1,553	\$2,081	\$2,013
TAB15-1/2	1/2	15"	1890	3000	2650	1500	--	--	\$1,594	\$1,577	\$2,028	\$2,075
TAB15-3/4	3/4	15"	2200	3700	3400	2700	1150	--	\$1,653	\$1,629	\$2,154	\$2,163
TAB18-1/2	1/2	18"	1890	3500	3100	2000	--	--	\$1,666	\$1,649	\$2,100	\$2,147
TAB18-1	1	18"	1725	4375	4080	3000	2100	1550	\$1,895	\$1,863	\$2,332	\$2,305
TAB18-1 1/2	1 1/2	18"	1990	5060	4830	3950	3000	2500	\$2,060	\$1,938	\$3,170	\$2,829
TAB24-1/2	1/2	24"	1298	5320	4826	3500	--	--	\$1,807	\$1,790	\$2,240	\$2,288
TAB24-3/4	3/4	24"	1600	6510	5900	4650	2750	--	\$1,891	\$1,874	\$2,391	\$2,400
TAB24-1	1	24"	1725	7000	6350	5000	3300	1775	\$1,996	\$1,964	\$2,433	\$2,406
TAB24-2	2	24"	1600	9114	8830	8090	7000	4400	\$2,690	\$2,479	\$4,310	\$3,399
TAB24-3	3	24"	1725	9800	9500	8700	7800	5000	--	\$2,562	--	\$3,245
TABPR27-1	1	27"	1400	8675	9480	7300	5200	--	\$2,448	\$2,415	\$2,885	\$2,858
TABPR27-1 1/2	1 1/2	27"	1600	10250	9700	8375	6000	2500	\$2,619	\$2,497	\$3,729	\$3,387
TABPR27-2	2	27"	1350	11200	10700	9300	8000	5200	\$2,775	\$2,565	\$4,395	\$3,485
TABPR30-2	2	30"	1176	11660	11000	9322	6700	--	\$2,851	\$2,641	\$4,471	\$3,561
TAB30-3	3	30"	1350	12982	12498	11465	10380	9470	--	\$2,803	--	\$3,486
TAB30-5	5	30"	1650	15832	15242	13982	12659	11550	--	\$2,938	--	\$3,823
TAB34-2	2	34"	1027	13652	12590	10000	8000	--	\$3,343	\$3,134	\$4,963	\$4,053
TAB34-3	3	34"	1175	16750	12896	14095	12000	9500	--	\$3,220	--	\$3,903
TAB34-5	5	34"	1416	19800	19000	17500	16000	14200	--	\$3,354	--	\$4,237
TABPR42-2	2	42"	820	18900	17002	11400	4000	--	\$2,948	\$3,738	\$5,568	\$4,658
TABPR42-3	3	42"	890	22100	20200	16970	9950	3600	--	\$3,954	--	\$4,509
TABPR42-5	5	42"	850	25600	24403	22250	18400	13900	--	\$4,132	--	\$5,017

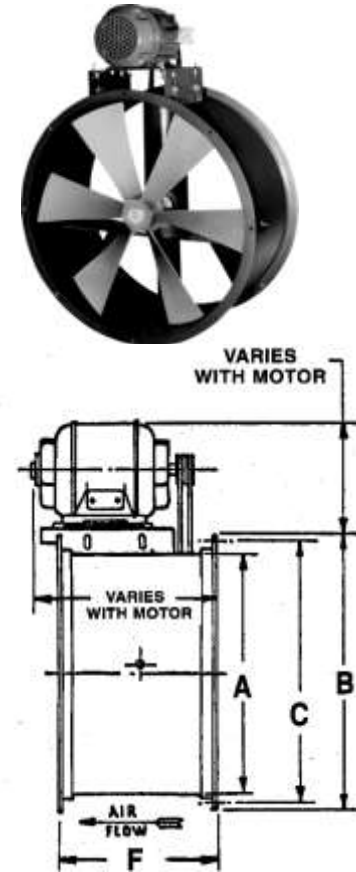

DIMENSIONS				
SIZE	A	B	C	F
12	12	14	13	12
15	15	17	16	12
18	18	20	19	12
24	24	27	25 5/8	12,16*
27	27	30	28 5/8	12,16**
30	30	33	31 5/8	12,16**
34	34	37	35 5/8	16
42	42	45	43 5/8	18
*2HP & UP ** 1 1/2 HP & UP				

TUBE AXIAL ACCESSORIES				
SIZE	MATCHING FLANGE \$	INLET/OUTLET GUARD \$	BELT GUARD \$	MOTOR COVER MODEL / LIST
12	57	91	\$245	48-154T \$330
15	60	93		
18	64	95		
24	86	102		
27	106	113	\$267	182-213T \$408
30	107	121		
34	111	166		
42	144	195	\$291	215-256T \$419

# BACKWARD INCLINE BLOWER ----- USI SERIES

## FEATURES:

- \* LEAD TIME = 10 WORK DAYS
- \* INCLUDES A WEATHER COVER
- \* UL762 LISTED
- \* SHAFT SEAL
- \* EASILY ACCESSIBLE CLEAN OUT DOOR

## OPTIONAL ACCESSORIES (CALL FOR PRICE)

- VIBRATION ISOLATORS
- GREASE CUP
- VAV PACKAGES
- INLET OR OUTLET GUARD

MODEL	HP	MAX RPM	CFM @ SP					WT LBS	ODP	
			1/2	3/4	1	1 1/2	2		1 PH	3 PH
USI-100	1/3	2189	769	629	495	--	--	115	\$1,854	---
	1/2	1150	954	866	738	499	--	117	\$1,813	\$1,786
USI-137	1/2	1150	1263	546	--	--	--	190	\$2,272	\$2,245
	3/4	1375	1745	1518	1027	--	--	192	\$2,306	\$2,255
	1	2327	2940	2181	2688	2400	2065	195	\$2,355	\$2,272
USI-161	3/4	1563	3264	3048	2819	1717	--	207	\$2,591	\$2,540
	1	1667	3607	3408	3264	2709	1037	210	\$2,640	\$2,557
	2	2055	4811	4674	4522	4212	3881	223	\$2,769	\$2,615
	3	2370	5533	5413	5293	5021	4745	279	\$3,051	\$2,693
USI-200	1	1274	4445	4094	3757	2147	--	245	\$3,369	\$3,286
	2	1563	5880	5611	5329	4785	4093	258	\$3,498	\$3,343
	3	1661	6861	6648	6404	5913	5443	314	\$3,779	\$3,422
USI-245	1	780	5933	5279	4503	-	--	598	\$3,762	\$3,679
	2	960	7761	7315	6792	5582	--	616	\$3,891	\$3,736
	3	1120	9319	8948	8566	7667	6607	687	\$4,172	\$3,814
	5	1330	11302	11014	10700	10056	9284	704	\$4,366	\$4,630

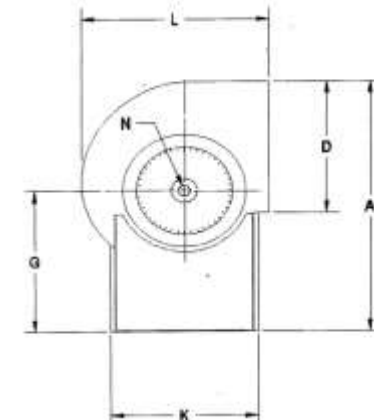
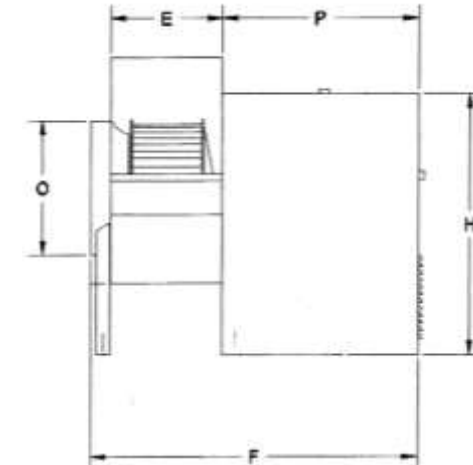

INTERMEDIATE & LARGER SIZES AVAILABLE - CONTACT THE FAN DEPT.

DIMENSIONS (INCHES)		OUTLET		*NO LEG ON BI-10		#Cabinet Width			SHAFT DIA	INLET	P	WT LBS
MODEL	A	D	E	F	G	H	#K	L	N	O		
BI-10	26-3/4	11-5/16	8-1/4	*	15-1/4	21-5/16	13-3/16	17-3/8	3/4	11	17-1/4	90
BI-12	33-1/16	13	9-7/8	33-1/4	20-1/16	29-1/8	16-9/16	20-1/2	1	12-7/16	21-1/8	157
BI-13	34-5/16	14-3/8	10-3/4	34-1/8	20-1/16	29-1/8	16-9/16	22-1/2	1	14-3/8	21-1/8	170
BI-15	35-13/16	15-3/4	12	35-3/8	20-1/16	29-1/8	16-9/16	24-11/16	1	15-7/8	21-1/8	180
BI-16	39-3/8	17-5/8	13-1/8	36-1/2	22	31	16-9/16	26-7/8	1-3/16	17-3/8	21-1/8	210
BI-18	41-1/4	19-3/8	14-1/2	37-7/8	22	31	16-9/16	29-5/8	1-3/16	19-3/8	21-1/8	220
BI-20	49-1/8	21-1/4	15-3/4	46-7/16	28	40-7/8	25-1/4	32-1/4	1-3/16	21-1/4	27-11/16	357
BI-22	51-1/2	23-5/8	17-5/8	48-5/16	28	40-7/8	25-1/4	35-5/8	1-3/16	23-5/8	27-11/16	390
BI-24	57-7/8	26	19-3/8	51-5/16	32	46-1/2	28-15/16	39	1-7/16	26	28-15/16	499

# ECONOMY-ROOF VENT (RELIEF/INTAKE) EMUA SERIES

## FEATURES

- \* RELIEF CFM GIVEN - SUPPLY DUTY DEDUCT 10% CFM
- \* LOW PROFILE ALUMINUM CONSTRUCTION
- \* INCLUDES BIRDSCREEN
- \* ONE PIECE CURB CAP
- \* LEAD TIME - 5 WORKING DAYS



EMUA RELIEF #	THROAT AREA (FT)	C F M @ S.P.					WT LBS	LIST PRICE	MOTOR* DAMPER	AUTO DAMPER	12" GALV CURB	LIST \$
		0.03	0.06	0.09	0.125	0.15						
12	0.91	422	597	731	862	944	18	\$169	\$219	\$50	POD-17.5	\$87
14	1.22	572	808	990	1166	1278	22	\$232	\$233	\$64	POD-19.5	\$97
18	1.96	911	1288	1577	1858	2035	32	\$334	\$249	\$80	POD-24.5	\$112

SIZE	THROAT AREA SQ. FT	DIMENSIONS			CURB OD	ROOF OPENING
		W	HT	C		
12	0.91	21	11	18.5	18"	14"
14	1.22	27	14	21	20.5"	16"
18	1.96	34	16	26	25.5"	22"

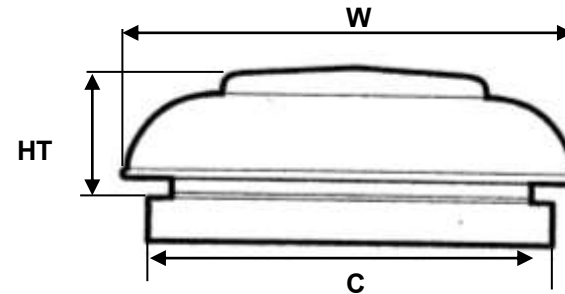

# ROOF VENTS RELIEF (VR10) - SUPPLY (VS10)



## FEATURES:

- \*ALUMINUM CONSTRUCTION
- \*LOW SILHOUETTE DESIGN
- \*BUILT IN WATER BAFFLE
- \*GALVANIZED BIRDSCREEN
- \*CUSTOM SIZES AVAILABLE
- \*ECONOMICAL GALVANIZED CONSTRUCTION AVAILABLE
- \*LEAD TIME = 10 WORK DAYS

MODEL NUMBER	SIZE	THROAT AREA	CFM @ SP					LIST PRICE		CURB 12"H	CURB PRICE	GRAVITY DAMPER	MOTORIZED DAMPER	DAMPER SIZE (IN)
			.031	.062	.093	.125	.25	VR	VS			VR (A)	VS (B)	
VR	12 X 12	1	530	750	920	1090	1530	\$345	362	POD-16	\$83	\$155	\$357	12 X 12
EXHAUST (1:1 RATIO)	15 X 15	1.56	811	1143	1392	1653	2237	404	456	POD-19	\$97	\$189	\$373	15 X 15
	18 X 18	2.3	1150	1640	2000	2360	3300	485	548	POD-22	\$105	\$241	\$406	18 X 18
	24 X 24	4	2000	2776	3444	4056	5624	587	653	POD-28	\$120	\$287	\$426	24 X 24
	30 X 30	6.3	3120	4250	5370	6310	8690	740	860	POD-34	\$140	\$397	\$489	30 X 30
VS SUPPLY (2:1 RATIO)	36 X 36	9	4360	5850	7290	8730	12060	1133	1,275	POD-40	\$164	\$442	\$789	36 X 36
	48 X 48	16	7200	9600	11200	14880	20640	1559	2,070	POD-52	\$210	\$574	\$894	48 X 48
	60 X 60	25	10750	14250	16750	20750	29500	2716	3,727	POD-64	\$300	\$793	\$960	60 X 60

## ACCESSORIES:

- HINGED TOP - ADD 10%
- INSECT SCREEN - ADD 10%
- ALUMINUM BIRDSCREEN - ADD 15%
- ANTI-CONDENSATE COATING - ADD \$6.00 PER SQ. FT.
- INSULATED TOP PANEL - ADD \$10.00 PER SQ. FT.
- GALVANIZED CONSTRUCTION - DEDUCT 50% (MAX SIZE 30 X 30)

## ACCESSORY PRICING:

- (A) = ABD-1 HORIZONTAL & COUNTER-BALANCE NO FLANGE
- (B) = DG-11 AIR CONTROL DAMPER NO FLANGE (DAMPER MOTORS 115V)

DIMENSIONS (IN)					
THROAT SIZE	A	C		Y	
		VR (1:1)	VS(2:1)	VR	VS
18 X 18	23 X 23	31 X 31	35 X 35	8	8
24 X 24	29 X 29	37 X 37	44 X 44	10	10
30 X 30	35 X 35	45 X 45	55 X 55	12	12
36 X 36	41 X 41	54 X 54	65 X 65	14	14
42 X 42	47 X 47	62 X 62	76 X 76	14	17
54 X 54	53 X 53	70 X 70	86 X 86	16	19
60 X 60	65 X 65	88 X 88	107 X 107	20	24

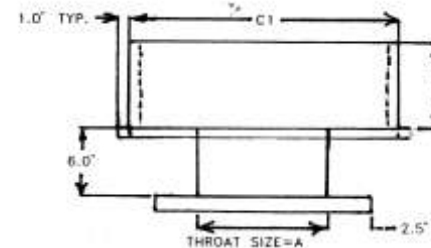

# FIXED LOUVERS

## Galvanized

GL Series

## Aluminum

AGL Series

The GL & AGL Louvers have a 37.5 degree blade which lets in 66% more air than a 45 degree "J" Blade Louver

### Features:

Drip Proof Construction

Frame & Stationary Blade:

18 Gauge Galvanized Steel

Birdscreen: .063 Aluminum Construction

Finish: 19 Gauge x 1/2" Galvanized Expanded Metal

Minimum: Mill

Maximum: 6" Wide x 12"High  
72" Wide x 96"High

### Options:

Flange Frame - Front or Rear (Specify)

18 x 16 Mesh Aluminum Insect Screen

16 Gauge Construction (Galvanized)

Standard Screen in Removable Frame

Prime Coat, Baked Enamel & Baked Epoxy Finishes

Note: Louvers are fabricated 1/4" under listed size unless specified "Actual or Exact"

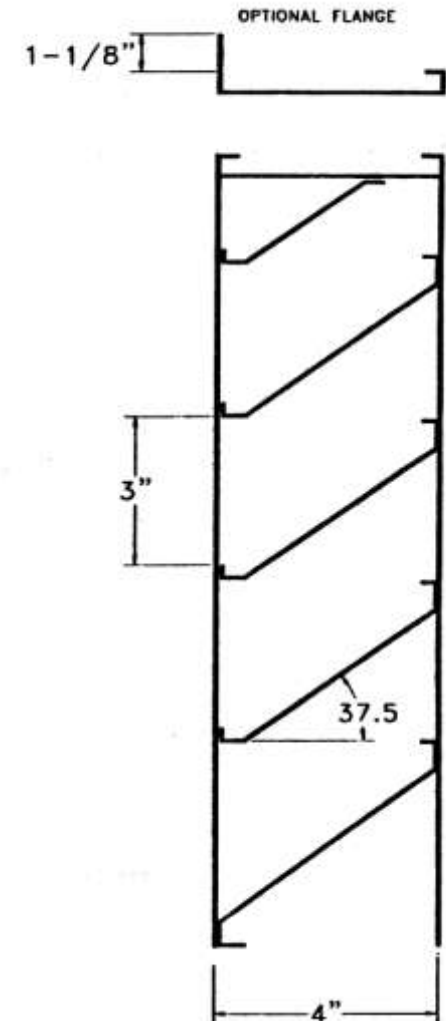

# FREE AREA FIXED LOUVERS

- GL4-37.5D GALVANIZED
- AGL4-375.D ALUMINUM (SEE ADDER)

FREE AREA CHART - SQ. FT  
WIDTH (IN)

	12	16	20	24	28	32	36	40	44	48	52	56	60	64	68	72
12	0.3	0.5	0.6	0.7	0.9	1.0	1.1	1.2	1.4	1.5	1.6	1.8	1.9	2.0	2.1	2.3
16	0.5	0.7	0.9	1.1	1.3	1.5	1.7	1.9	2.1	2.3	2.5	2.7	2.9	3.1	3.3	3.4
20	0.6	0.9	1.1	1.4	1.6	1.9	2.1	2.4	2.6	2.9	3.1	3.4	3.6	3.9	4.1	4.4
24	0.8	1.2	1.5	1.8	2.1	2.5	2.8	3.1	3.4	3.8	4.1	4.4	7.4	5.1	5.4	5.7
28	1.0	1.4	1.8	2.2	2.6	3.0	3.4	3.8	4.2	4.5	4.9	5.3	5.7	6.1	6.5	6.9
32	1.2	1.6	2.0	2.5	2.9	3.4	3.8	4.3	4.7	5.1	5.6	6.0	6.5	6.9	7.3	7.8
36	1.4	1.9	2.4	2.9	3.4	4.0	4.5	5.0	5.5	6.0	6.5	7.1	7.6	8.1	8.6	9.1
H																
E																
I																
G																
H																
T																
40	1.5	2.1	2.7	3.3	3.9	4.5	5.1	5.6	6.2	6.8	7.4	8.0	8.6	9.2	9.7	10.3
44	1.7	2.3	2.9	3.6	4.2	4.9	5.5	6.1	6.8	7.4	8.0	8.7	9.3	10.0	10.6	11.2
48	1.9	2.6	3.3	4.0	4.7	5.4	6.2	6.9	7.6	8.3	9.0	9.7	10.4	11.2	11.9	12.6
52	2.0	2.8	3.6	4.4	5.2	6.0	6.7	7.5	8.3	9.1	9.9	10.6	11.4	12.2	13.0	13.8
56	2.2	3.0	3.8	4.7	5.5	6.3	7.2	8.0	8.8	9.7	10.5	11.3	12.2	13.0	13.8	14.7
60	2.4	3.3	4.2	5.1	6.0	6.9	7.8	8.7	9.7	10.6	11.5	12.4	13.3	14.2	15.1	16.0
64	2.6	3.5	4.5	5.5	6.5	7.4	8.4	9.4	10.4	11.3	12.3	13.3	14.3	15.2	16.2	17.2
68	2.7	3.7	4.8	5.8	6.8	7.8	8.9	9.9	10.9	11.9	13.0	14.0	15.0	16.0	17.1	18.1
72	2.9	4.0	5.1	6.2	7.3	8.4	9.5	10.6	11.7	12.8	13.9	15.0	16.1	17.2	18.3	19.5
76	3.1	4.2	5.4	6.6	7.8	8.9	10.1	11.3	12.4	13.6	14.8	16.0	17.1	18.3	19.5	20.6
80	3.2	4.4	5.7	6.9	8.1	9.3	10.5	11.8	13.0	14.2	15.4	16.7	17.9	19.1	20.3	21.5
84	3.4	4.7	6.0	7.3	8.6	9.9	11.2	12.5	13.8	15.1	16.4	17.7	19.0	20.3	21.6	22.9
88	3.6	5.0	6.3	7.7	9.0	10.4	11.8	13.1	14.5	15.9	17.2	18.6	20.0	21.3	22.7	24.1
92	3.7	5.1	6.6	8.0	9.4	10.8	12.2	13.6	15.1	16.5	17.9	19.3	20.7	22.1	23.6	25.0
96	3.9	5.4	6.9	8.4	9.9	11.4	12.9	14.4	15.9	17.4	18.9	20.4	21.8	23.3	24.8	26.3

FREE AREA VELOCITY = CFM/FREE AREA (SQ. FT)

PRESSURE DROP - INCHES OF WATER  
(IN.W.C.)

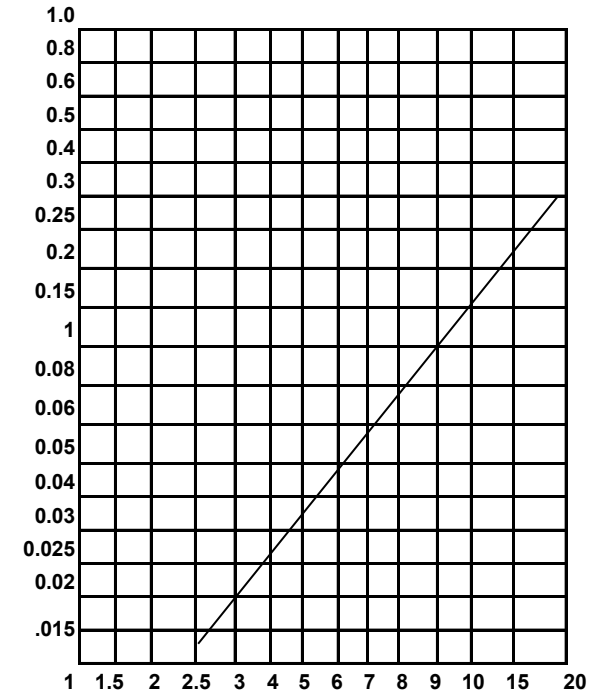

Velocity Through Free Area  
FPM x 100  
PRESSURE DROP  
INTAKE



# LIST PRICE - FIXED LOUVERS

- GL 4-37.5D GALVANIZED

- AGL 4.37.5D ALUMINUM - **SEE ADDER**

**PRICING NOTES:**

MAXIMUM SINGLE SELECTION CONSTRUCTION IS 72" WIDE X 96" HIGH

MULTIPLE SECTION CONSTRUCTION TO BE PRICED AS TWO OR MORE SECTIONS OF EQUAL SIZE

SEE OPTIONAL ADDER FOR ALUMINUM CONSTRUCTION

	12	16	20	24	28	32	36	40	44	48	52	56	60	64	68	72
12	95	104	113	125	134	141	150	159	171	180	187	196	205	217	226	233
16	113	125	136	148	159	171	182	194	208	219	231	242	254	265	277	288
20	134	148	161	175	187	203	217	231	245	261	274	282	300	314	330	344
24	150	168	182	198	217	233	249	277	284	300	314	332	348	367	381	399
28	168	187	205	226	242	263	284	300	321	337	358	378	391	415	434	452
H	32	187	208	231	251	274	295	314	337	358	381	401	422	445	464	507
E	36	205	228	254	277	300	323	346	371	394	417	445	468	491	514	563
I	40	226	261	277	302	330	355	381	406	436	461	487	514	540	565	618
G	44	242	272	300	330	358	387	415	445	471	498	528	556	586	614	671
H	48	261	291	323	353	383	415	447	480	507	540	572	602	634	664	727
T	52	279	314	346	381	415	447	482	517	549	584	618	648	683	717	784
	56	298	334	369	406	441	480	514	551	586	623	657	694	729	768	840
	60	314	353	392	429	471	507	544	586	623	664	701	738	780	817	895
	64	334	376	415	459	498	540	579	620	664	703	745	784	826	867	948
	68	353	394	439	482	526	567	611	655	701	745	787	830	874	918	1,003
	72	381	417	464	510	554	600	646	692	738	784	830	876	920	966	1,059
	76	390	439	484	533	584	632	678	727	775	826	872	920	969	1,017	1,114
	80	406	459	507	560	609	660	713	761	814	863	913	966	1,015	1,068	1,167
	84	427	480	533	586	641	692	745	798	851	906	957	1,010	1,063	1,116	1,222
	88	445	498	556	611	667	722	780	833	888	943	1,001	1,056	1,109	1,165	1,278
	92	464	498	579	637	694	752	810	867	930	987	1,045	1,102	1,160	1,218	1,333
	96	482	542	602	664	724	784	844	906	964	1024	1,084	1,144	1,206	1,266	1,386

**OPTIONS**

ALUMINUM CONSTRUCTION

1 1/2" FLANGE

INSECT SCREEN IN REMOVABLE FRAME

STANDARD SCREEN IN REMOVABLE FRAME

STAINLESS STEEL CONSTRUCTION

**ADDER ( X LIST )**

0.50

0.10

0.25

0.10

2.70

**GALVANIZED LOUVER FINISH PRICES:**

PRIME COAT

BAKED ENAMEL - STD COLOR

BAKED ENAMEL - COLOR MATCH

**NET MIN/PER SQ.FT**

\$75 \$6

\$100 \$12

\$150 \$14

# OPERABLE LOUVERS

Galvanized  
GA Series

Aluminum  
AGA Series

The GA- AGA Louver has a 37.5 degree blade which lets in 66% more air than a 45 degree "J" Blade Louver

## Features:

Drip Proof Construction

Frame :

14 ga. Galvanized Steel Jamb  
18 ga. Galvanized Steel Cover Channels

Blades: 18 ga. Galvanized Steel

Axes: 1/2" Diameter Zinc Plated Steel

Bearings: Permanently Lubricated Oilite Bronze

Linkage: Commercial Grade Riveted Brass Pivots

Screen: 1/2" x 1/2" Galvanized Mesh

Minimum 12" Wide x 12" High

Maximum 48" Wide x 96" High

Multi-Sections-Unlimited

## Options:

Flange Frame - Front or Rear (Specify)

Insect Screen in removable Frame

Jackshafts (for 2 or more louvers)

Standard Screen in Removable Frame

Wall Sleeves

Electric & Manual Operators (actuators)

16 Ga. Blades & Channels (GA only)

Jamb & Blade Seals

Note: Louvers are fabricated 1/4" under listed size unless specified "Actual or Exact"

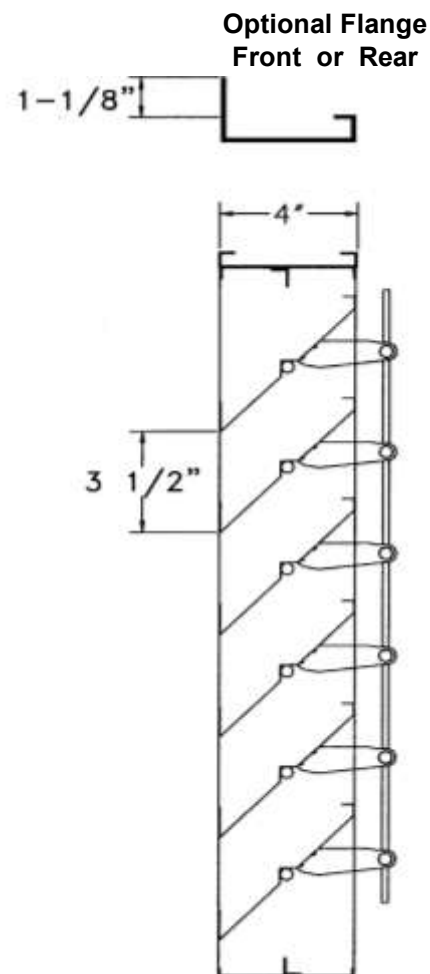

# FREE AREA OPERABLE LOUVERS

- GA 4-37.5D GALVANIZED
- AGA 4-375.D ALUMINUM (SEE ADDER)

FREE AREA CHART - SQ. FT

WIDTH (IN)

	12	16	20	24	28	32	36	40	44	48	52	56	60	64	68	72
12	0.3	0.4	0.5	0.6	0.7	0.8	0.9	1.0	1.1	1.3	1.4	1.5	1.6	1.7	1.8	1.9
16	0.4	0.6	0.8	1.0	1.1	1.3	1.5	1.7	1.9	2.0	2.2	2.4	2.6	2.8	2.9	3.1
20	0.5	0.7	0.9	1.1	1.3	1.5	1.8	2.0	2.2	2.4	2.6	2.8	3.0	3.2	3.4	3.6
24	0.7	0.9	1.2	1.5	1.7	2.0	2.3	2.6	2.8	3.1	3.4	3.6	3.9	4.2	4.4	4.7
28	0.9	1.2	1.5	1.8	2.0	2.3	2.6	2.9	3.2	3.5	3.8	4.1	4.4	4.7	4.9	5.2
32	0.9	1.3	1.7	2.2	2.6	3.0	3.5	3.9	4.3	4.7	5.2	5.6	6.0	6.4	6.9	7.3
36	1.1	1.5	1.9	2.4	2.8	3.3	3.7	4.1	4.6	5.0	5.5	5.9	6.3	6.8	7.2	7.7
40	1.2	1.7	2.2	2.8	3.3	3.8	4.3	4.8	5.3	5.8	6.3	6.8	7.3	7.9	8.4	8.9
44	1.3	1.8	2.4	2.9	3.4	4.0	4.5	5.1	5.6	6.1	6.7	7.2	7.8	8.3	8.8	9.4
48	1.5	2.0	2.6	3.2	3.8	4.4	4.9	5.5	6.1	6.7	7.3	7.8	8.4	9.0	9.6	10.2
52	1.6	2.3	3.0	3.7	4.3	5.0	5.7	6.4	7.1	7.7	8.4	9.1	9.8	10.5	11.1	11.8
56	1.7	2.4	3.1	3.8	4.5	5.2	5.9	6.6	7.3	8.0	8.7	9.4	10.1	10.8	11.5	12.2
60	1.8	2.6	3.4	4.2	5.0	5.7	6.5	7.3	8.1	8.9	9.6	10.4	11.2	12.0	12.8	13.5
64	2.0	2.9	3.7	4.5	5.4	6.2	7.1	7.9	8.7	9.6	10.4	11.3	12.1	12.9	13.8	14.6
68	2.1	3.0	3.8	4.7	5.6	6.5	7.4	8.2	9.1	10.0	10.9	11.8	12.6	13.5	14.4	15.3
72	2.2	3.2	4.2	5.2	6.1	7.1	8.1	9.1	10.1	11.0	12.0	13.0	14.0	15.0	15.9	16.9
76	2.4	3.4	4.4	5.5	6.5	7.5	8.5	9.5	10.6	11.6	12.6	13.6	14.6	15.7	16.7	17.7
80	2.5	3.5	4.5	5.6	6.7	7.7	8.8	9.8	11.0	12.0	13.1	14.1	15.2	16.3	17.4	18.4
84	2.5	3.6	4.7	5.8	6.9	8.0	9.1	10.2	11.4	12.5	13.6	14.7	15.8	16.9	18.0	19.1
88	2.8	4.0	5.2	6.3	7.5	8.7	9.9	11.1	12.2	13.4	14.6	15.8	17.0	18.1	19.3	20.5
92	2.9	4.1	5.3	6.5	7.8	9.0	10.2	11.4	12.6	13.9	15.1	16.3	17.5	18.7	20.0	21.2
96	3.0	4.3	5.6	6.9	8.2	9.4	10.7	12.0	13.3	14.6	15.8	17.1	18.4	19.7	21.0	22.2

FREE AREA VELOCITY = CFM/FREE AREA (SQ. FT)

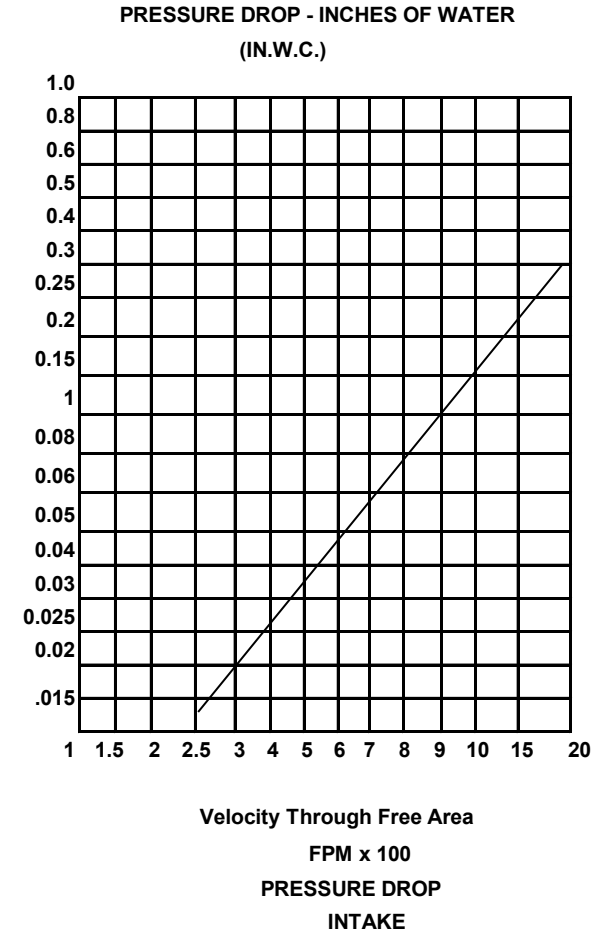

# LIST PRICE - OPERABLE LOUVERS

# GA 4-37.5 D GALVANIZED

# AGA 4-37.5D ALUMINUM - **SEE ADDER**

**NOTES:**

MAXIMUM SINGLE SECTION CONSTRUCTION IS 48" WIDE X 96" HIGH

MULTIPLE SECTION CONSTRUCTION TO BE PRICED AS TWO OR MORE SECTION OF EQUAL SIZE

SEE OPTIONAL ADDER FOR ALUMINUM CONSTRUCTION

WIDTH (IN)										
	12	16	20	24	28	32	36	40	44	48
12	217	224	231	242	249	258	270	277	291	300
16	235	249	263	277	286	300	309	321	332	348
20	265	284	304	323	332	346	355	369	383	399
24	298	321	348	374	392	404	417	431	447	464
28	339	367	392	415	429	447	464	484	503	524
H	32	369	401	431	464	489	512	533	554	595
E	36	406	436	466	496	519	544	565	588	634
I	40	443	468	498	524	547	570	593	618	671
G	44	484	514	544	574	600	625	650	678	733
H	48	519	551	586	614	644	674	706	733	789
T	52	544	577	609	644	671	701	731	761	823
	56	574	609	646	683	713	745	780	807	872
	60	604	639	674	708	745	784	819	853	925
	64	637	671	710	750	784	819	856	890	959
	68	678	717	759	803	840	879	916	953	1031
	72	713	763	812	863	904	948	987	1029	1114
	76	747	807	860	923	966	1013	1054	1109	1158
	80	784	856	911	987	1033	1082	1126	1197	1250
	84	823	906	964	1054	1105	1156	1204	1292	1349
	88	863	959	1022	1126	1181	1236	1287	1393	1455
	92	904	1015	1082	1204	1262	1322	1377	1504	1571
	96	948	1075	1146	1287	1349	1414	1472	1624	1695
										1758

OPTIONS	
Item	Adder ( X List)
AGA - .063 Aluminum Construction	0.50
Frame and Blades	
* 1 1/2" Flange	0.10
* Insect Screen In Removable Frame	0.25
* Stainless Steel Construction	2.70
* Jamb Seals	0.10
* Blade Seals	0.05
* Jackshaft	\$20/FT

FINISH TYPE	Net Min/Per Sq Ft	
Prime Coat	\$75	\$6.00
Baked Enamel-Std Color	\$100.00	\$12.00
Baked Enamel-Color Match	\$150.00	\$14.00
ACTUATORS ---- SEE SECTION 7		

Louvers are construction 1/4" under opening size

# AIR CONTROL DAMPERS

## DG-11 Parallel Blade Dampers

### Features:

**Frame:** 3 1/8" x 5/8" x 14 ga. Roll formed galvanized steel hat section with welded corners

**Blades:** 16 ga. Press formed galvanized steel.

**Bearings:** Permanently lubricated oilite bronze, press fit into frame.

**Axes:** 1/2" Diameter zinc plated pin

**Linkage:** Commercial grade riveted with brass pivots

**Tie Rods:** 1/4" Diameter plated steel

**Shaft:** 6" x 1/2" Diameter plated steel

**Finish:** Mill galvanized

**Minimum:** 6" Wide x 12" High

**Maximum:** Single section - 48" Wide x 96" High

### Options:

**Flange Frame:** Specify (Front or Rear)

**Vinyl Blade Seal**

**Flexible Stainless Steel Jamb Seal**

**Vertical Blade Construction**

**Actuators, Factory or Field Installed**

**Manual Operators**

**Opposed Blade Dampers Available**

**Wall Sleeves**

**Screens are NOT an Option**

**\*Rear Side is the Linkage Edge**

**Note: Dampers are fabricated 1/4" under size unless specified actual or exact."  
Dampers must be installed square and free from racking.**

**Optional Flange  
Rear or Front**

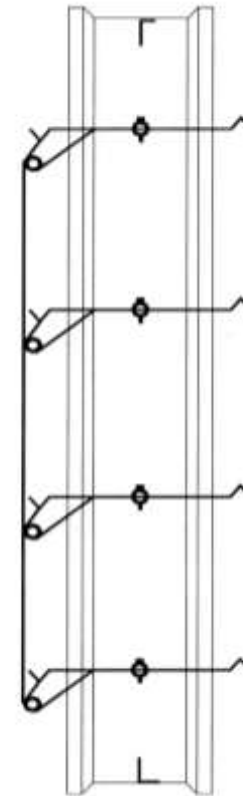

# LIST PRICE: DG-11 OPERATING CONTROL DAMPER

**NOTES:**

**MAXIMUM SINGLE SECTION CONSTRUCTION IS 48" WIDE X 72" HIGH  
 MULTIPLE SECTION CONSTRUCTION TO BE PRICED AS TWO OR MORE SECTIONS OF EQUAL SIZE**

WIDTH (IN)											
	12	16	20	24	28	32	36	40	44	48	
12	80	85	91	98	105	108	115	121	126	133	
16	90	96	105	110	118	125	133	139	148	154	
20	113	121	130	138	146	151	159	168	176	184	
24	123	131	141	149	158	168	176	184	196	204	
28	143	154	164	173	183	193	204	213	223	233	
H	32	156	166	179	189	199	213	223	233	246	256
E	36	176	189	201	216	229	241	254	267	281	292
I	40	188	201	214	229	242	256	271	284	297	312
G	44	206	221	234	251	266	281	296	312	326	340
H	48	216	233	247	264	281	296	312	329	342	359
T	52	234	251	267	287	304	321	337	355	372	389
	56	246	264	281	299	317	334	354	372	389	407
	60	272	291	312	330	349	370	389	407	428	447
	64	282	301	324	342	364	384	405	423	445	465
	68	307	326	349	372	392	414	433	457	478	498
	72	317	340	364	384	417	430	453	473	497	520

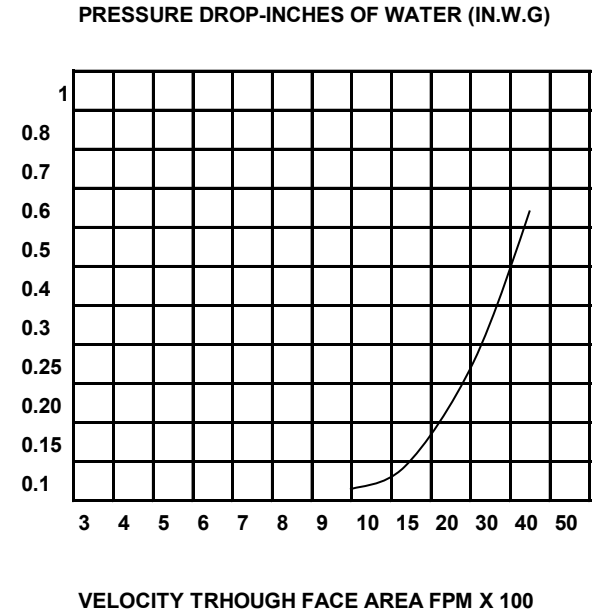

**Options:**

Item	Adder (x List)
*Vinyl Blade Seals	0.10
*Flexible stainless Steel Jamb Seal	0.10
* 1 1/2" Flange (Around Frame)	0.20
** Jackshaftering	\$20 List/Foot
*.080 Aluminum Construction	0.50
(Maximum 24" Wide with Jamb Seals - 48" Wide without Jamb Seals- All Multi-Section Units Must Have Jackshafts)	
*304 2B Stainless Steel Construction	2.70
Actuators-----See Section 7	

# ECONOMY BACK DRAFT DAMPER SHUTTER

## ABD-1

### Features:

#### Vertical or Upflow Mounted

Frame: .070 Extruded Aluminum

Blades: .025 Roll formed aluminum with polyurethane foam edge seals

Bearing: Nylon, press it into frame

Axles: 3/16" Diameter nylon

Linkage: Plated steel linkage bar

Finish: Mill aluminum

Minimum: Single blade 6" wide x 6" high

Maximum Velocity: 900 fpm

Maximum Static Pressure: 1.0" wg

### Options:

#### Counter Balance

1 1/4" Flange (Specify Front or Rear)

Horizontal Mount (up blast only)

Special Finishes

**\*Note:** All dampers are fabricated 1/4" under listed size unless specified "actual or exact"

Back draft dampers (Shutter) offered with fans are available in specific sizes but are less expensive and may match your requirements

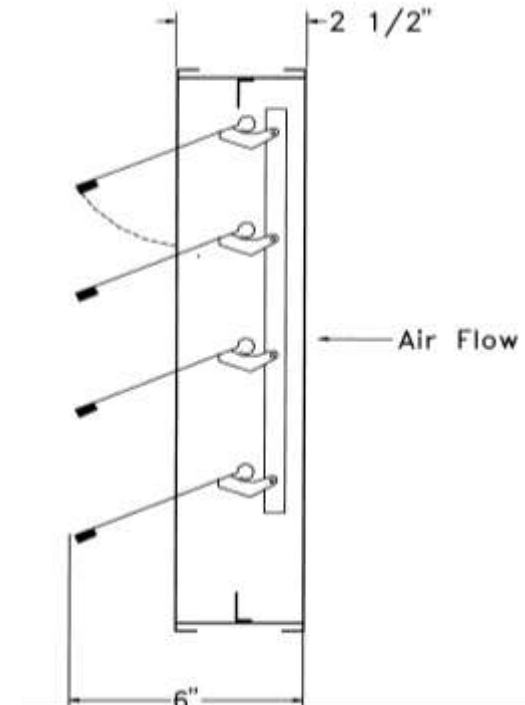

# LIST PRICE: GRAVITY DAMPER ABD-1

**FEATURES:**

- \* ALL ALUMINUM
- \* SIZES MADE TO ORDER
- \* HORIZONTAL OR UPFLOW APPLICATIONS
- \* FLANGES STANDARD

	LIST PRICES		WIDTH						
	8	12	16	20	24	28	32	36	40
8	102	103	115	125	133	140	149	162	176
12	103	115	125	136	140	149	162	176	179
16	125	136	140	149	162	176	179	189	201
20	149	162	176	179	189	201	202	213	227
24	179	189	201	205	213	227	236	251	255
28	202	213	227	236	251	254	263	270	288
32	236	251	255	263	270	288	294	304	314
36	263	270	288	294	301	314	319	328	338
40	294	304	314	319	328	338	353	362	369
44	319	328	338	353	362	369	376	388	394
48	354	362	369	376	388	394	400	419	427
52	407	425	459	475	499	506	526	555	574

H  
E  
I  
G  
H  
T

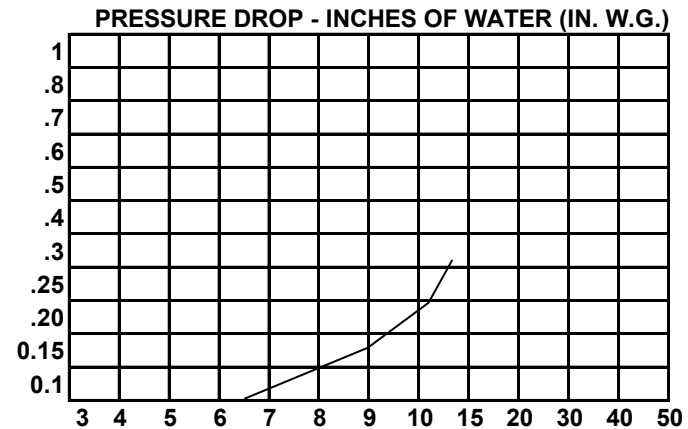

USE MULTIPLE DAMPERS FOR LARGER SIZES

**ACCESSORIES:**

- FLANGE (SPECIFY LOCATION) - NO CHARGE
- COUNTER-BALANCE WEIGHTS - ADD 18%
- HORIZONTAL MOUNT (UPFLOW ONLY) - ADD 10%



# BACKDRAFT - SHUTTERS COUNTER BALANCE GRAVITY

**BD-11**

Vertical

**BD-21**

Horizontal Mount Upflow

**BD-22**

Horizontal Mount Down Flow

## FEATURES:

Frame: 14 Guage roll formed channel with welded corners

Blades: .080 Formed aluminum

Bearing: Nylon pressed into frame

Axles: 1/2" Diameter zinc plated steel

Linkage: Plated steel

Finish: Mill Galvanized

## Sizes:

Minimum: Single blade 6" wide x 8" high

Maximum: (single panel) 48"wide x 72" high

## Options:

Flanges (specify Front or Rear)

Vinyl Blade Seals

Sleeve

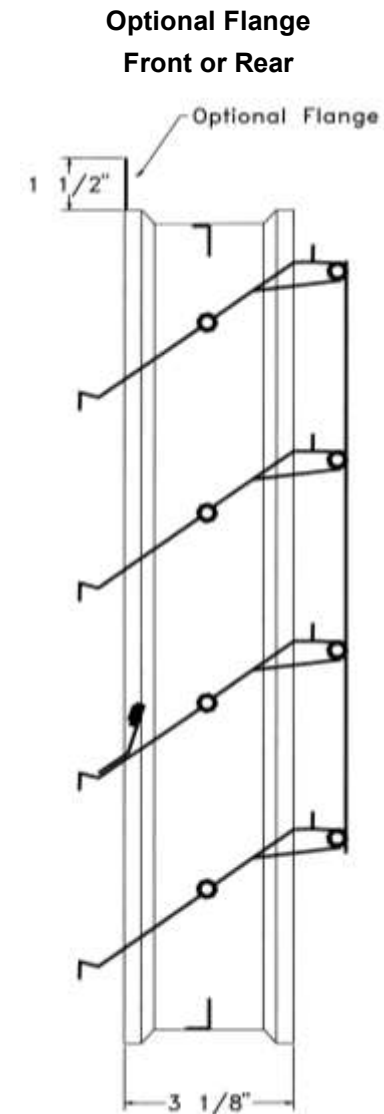

# LIST PRICE - BACKDRAFT DAMPERS

- BD 11- Vertical Mount
- BD 21- Horizontal Up Flow (see price adder)
- BD 22- Horizontal Down Flow (see price adder)

1. Maximum Single Section Construction Is 48" Wide x 72" High
2. Mutple Section Construction To Be Priced As Two Or More Sections Of Equal Size

	WIDTH (IN)									
	12	16	20	24	28	32	36	40	44	48
14	148	157	164	173	183	190	199	209	214	223
16	181	192	201	212	223	233	245	257	266	277
20	199	210	223	236	247	260	273	284	297	310
24	227	240	257	269	284	301	314	328	343	358
28	242	258	275	292	306	325	341	358	375	389
H 32	260	279	295	314	332	349	367	386	402	421
E 36	306	330	352	376	399	424	448	471	495	517
I 40	323	349	375	399	424	448	472	498	524	550
G 44	352	380	408	435	463	491	519	546	574	602
H 48	369	399	430	458	487	517	546	574	605	635
T 52	395	428	461	493	524	557	590	620	655	686
56	421	458	495	528	563	598	633	666	703	738
60	447	485	526	563	600	638	677	712	753	790
64	472	515	559	598	638	679	720	758	801	841
68	500	544	590	633	675	720	764	805	851	893
72	526	574	624	666	714	760	806	851	899	945

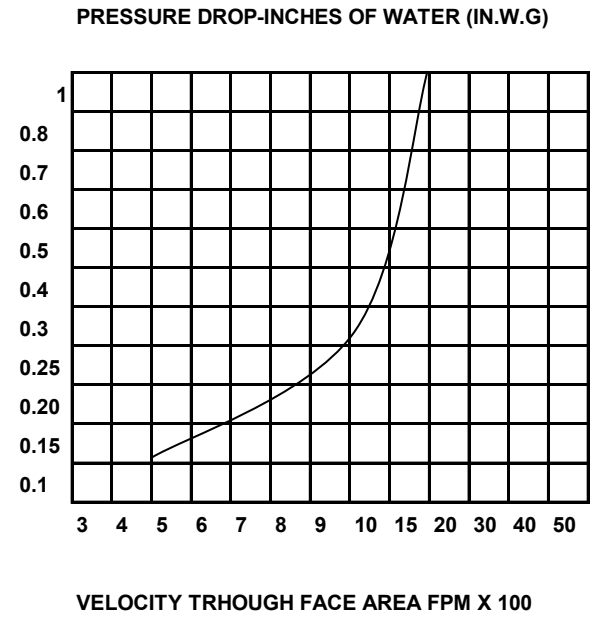

- Optional Construction Item Operators (actuators) see section 7
- BD-21 Horizontal Upflow -- List x 1.15
- BD-22 Horizontal Downflow -- List x 1.20
- Flange Frame --- List 1.20
- Vinyl Blade Seals --- List x 1.10
- All Aluminum Construction -- List x 1.50

# ACTUATOR SELECTION GUIDE

Actuators are selected by the inches of torque required to operate the damper or louver

1. Determine the total sq. inches of the damper (height x width)
2. Divide the total square inches by 144 (square inches in one square foot) to get the total square foot of the damper
3. Multiply the total sq. foot of the damper by the torque required to open a single sq. foot
4. Choose an actuator that exceeds the torque requirement.

Example:

- A.  $48 \times 48 = 2304$  sq inches
- B.  $2304$  sq inches divided by  $144 = 16$  sq feet
- C.  $16$  sq ft x  $1.76$  (torque per sq ft - below) =  $28.16$  inch lbs of torque required to open this  $48" \times 48"$  damper
- D. An LF-120v both with  $35"$  olbs of torque exceed the  $28.16"$  lbs required to operate the louver

## Manual Actuators

Manual locking quadrant for 1/2" diameter control rods	\$17.00
Damper/Adjustable Louver push-pull rod with wing nut lock	\$74.00
Chain operator with 6 feet of chain	\$83.00
Each additional foot of chain	\$10.00

## Electric Actuators

Belimo Model	Factory Mounted or with External Kit		
	Voltage	Torque	External Kit
AF- 120	120 VAC	133 IN. LBS	\$886.00
AF- 230	230 VAC	133 IN. LBS	\$978.00
AF- 24	24 VAC	133 IN. LBS	\$793.00
NF-120	120 VAC	60 IN. LBS	\$627.00
NF- 230	230 VAC	60 IN. LBS	\$720.00
NF - 24	24 VAC	60 IN. LBS	\$609.00
LF - 120	120 VAC	35 IN. LBS	\$535.00
LF - 230	230 VAC	35 IN. LBS	\$609.00
LF - 24	24 VAC	35 IN. LBS	\$517.00
TF - 120	120 VAC	18 IN. LBS	\$277.00
TF - 24	24 VAC	18 IN. LBS	\$277.00
Auxiliary Switch	For AF,NF, & LF Series (SPDT)		\$92.00

## Siemens Model

GMA -221	120 VAC	60 IN LBS	\$535.00
Transformer	460/277/240/ to 120v		\$148.00

# WALL SHUTTERS SIZED TO OPENING

ALL ALUMINUM CONSTRUCTION (12" - 48")

**\*\* 5 DAY LEAD TIME FOR 12"- 48"**

SIZE EXHAUST SHUTTER ID TO MATCH THE OPENING

SIZE SUPPLY SHUTTERS ID 1/2" SMALLER THAN WALL OPENING

DUCT MOUNTED SHUTTERS (NO FLANGE) ( SIZE TO THE DUCT DIMENSIONS

ADD MODEL # BEFORE THE SIZE 3200 = EXHAUST, 3100 = SUPPLY, 3000 = DUCT MOUNTED

OPENING SIZE	SHUTTER ID	SHUTTER OD	LIST PRICE
12 X 12	12 X 12	15 X 15	61
15 X 15	15 X 15	18 X 18	77
18 X 18	18 X 18	21 X 21	94
20 X 20	20 X 20	23 X 23	105
24 X 24	24 X 24	27 X 27	133
30 X 30	30 X 30	33 X 33	177
36 X 36	36 X 36	39 X 39	341
42 X 42	42 X 42	45 X 45	343
48 X 48	48 X 48	51 X 51	472

MOTOR KIT 115/230V 12" - 48" SQ	LIST \$157
TRANSFORMER 460V - 230/115V	LIST \$134

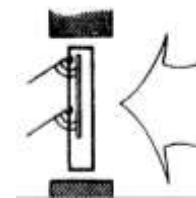
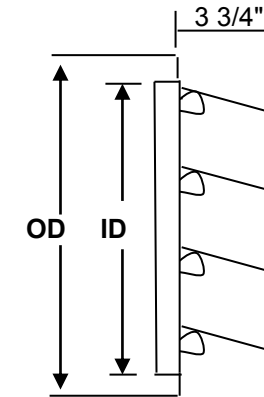

DUCT 3000 SERIES

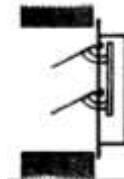

SUPPLY  
3100 SERIES



EXHAUST  
3200 SERIES

\*SHUTTER MADE 1/4" UNDERSIZE

RECTANGULAR SHUTTERS (DAMPERS) AVAILABLE CONSULT "THE FAN DEPT"

INTERMEDIATE SIZED SHUTTERS AVAILABLE CONSULT "THE FAN DEPT"

\*\* SAVE 25% BY REQUESTING 10 DAYS FOR PRODUCTION

## BACKDRAFT DAMPERS - ROUND OR SQUARE

### BACKDRAFT DAMPERS - 3600 SERIES

\*GALVANIZED STEEL

\*SPRING LOADES

\*ALL METAL

\*VERTICAL OR HORIZONTAL MOUNTING

\*SIZED IN INCHES NOT MM.

\*DAMPERS IN STOCK - ALLOW 24 HRS TO PROCESS

DAMPER DIA "IN"	LIST PRICE
6"	\$65
8"	67
10"	75
12"	86
14"	95
16"	110
18"	122
20"	134
22"	146
24"	158



# ELECTRIC DUCT HEATERS (DB-DC)



- FEATURES :
- \*NICKLE CHROME HEATER WIRES
  - \*COMPLETE UNIT (EXCEPT T STAT)
  - \*24 VOLT CONTROL CONTACTOR
  - \*AUTOMATIC LIMIT SWITCH
- \*CUSTOM MADE TO FIT THE DUCT
  - \*LEFT HAND OFF SET CONTROL BOX
  - \*SLIP- IN INSTALLATION

Model #	KW	BTU	VOLTS/ PHASE	STAGES	AMPS	DUCT WIDTH (IN)	DUCT HEIGHT (IN)	MINIMUM REQUIRED @ 78 DEGREES		FAN BOOK LIST* PRICE
								CFM	FPM	
DB 5-1-230	5	17060	230-1	1	21.7	12	8	350	520	\$327
DB 10-1-230	10	34120	240-1	2	41.7	18	10	675	540	\$500
DB 15-1-240	15	51180	240-1	2	62.5	18	12	945	630	\$685
DB 20-1-240	20	68240	240-1	2	83.3	20	12	1185	710	\$743
DC 25-1-240	25	85300	240-1	3	104.2	20	16	1510	680	\$1,072
DB 2-1-277	2	6824	277-1	1	7.2	12	8	180	265	\$292
DB 3.5-1-277	3.5	11942	277-1	1	12.6	12	8	275	410	\$296
DB 5-1-277	5	17060	277-1	1	18.1	12	8	350	520	\$375
DB 5-3-208	5	17060	208-3	1	13.9	12	8	350	520	\$479
DB 10-3-208	10	34120	208-3	1	27.8	18	10	675	540	\$516
DB 15-3-208	15	51180	208-3	1	41.6	18	12	945	630	\$599
DC 20-3-208	20	68240	208-3	2	55.5	20	12	1185	710	\$1,193
DC 25-3-208	25	85300	208-3	2	69.4	20	16	1510	680	\$1,344
DC 30-3-208	30	102360	208-3	2	83.3	24	16	1815	680	\$1,574
DC 35-3-208	35	119420	208-3	3	97.2	24	16	2055	770	\$1,812
DC 40-3-208	40	136480	208-3	3	111	24	16	2350	880	\$1,838
DC 45-3-208	45	153540	208-3	3	124.9	30	16	2635	790	\$2,130
DC 50-3-208	50	170600	208-3	3	138.8	30	16	2935	880	\$2,126
DB 5-3-240	5	17060	240-3	1	12	12	8	350	520	\$480
DB 10-3-240	10	34120	240-3	1	24.1	18	10	675	540	\$518
DB 15-3-240	15	51180	240-3	1	36.1	18	12	945	630	\$577
DB 19.9-3-240	19.9	67898.8	240-3	2	47.9	20	12	1185	710	\$712
DC 25-3-240	25	85300	240-3	2	60.1	20	16	1510	680	\$1,351
DC30-1-240	30	102360	240-1	2	125	24	16	1815	680	\$1,427
DC 35-3-240	35	119420	240-3	3	84.2	24	16	2055	770	\$1,660
DC 40-3-240	40	136480	240-3	3	96.2	24	18	2340	780	\$1,873
DC 45-3-240	45	153540	240-3	3	108.3	30	16	2635	790	\$1,909
DC 49.8-3-240	49.8	169917.6	240-3	3	119.8	30	16	2935	880	\$1,958
DB 5-3-480	5	17060	480-3	1	6	12	8	350	520	\$488
DB 10-3-480	10	34120	480-3	1	12	18	10	675	540	\$530
DB 15-3-480	15	51180	480-3	1	18	18	12	945	630	\$550
DB 20-3-480	20	68240	480-3	2	24.1	20	12	1185	710	\$642
DC 25-3-480	25	85300	480-3	2	30.1	20	16	1510	680	\$855
DC 30-3-480	30	102360	480-3	2	36.1	24	16	1815	680	\$901
DC 35-3-480	35	119420	480-3	3	42.1	24	16	2055	770	\$1,021
DC 40-3-480	40	136480	480-3	3	48.1	24	18	2340	780	\$1,937
DC 50-3-480	50	170600	480-3	3	60.1	30	16	2935	880	\$1,973

### APPLICATION NOTES:

1. Heaters made to fit the duct for larger or smaller duct (shown above) Contact the "Fan Dept." for pricing
2. For different stages or KW, contact the "Fan Dept." for pricing
3. Right hand off-set and bottom mounted control boxes, contact the "Fan Dept." for pricing
4. For 115 volt, control contact the "Fan Dept." for pricing
5. For flanged heaters, contact the "Fan Dept." for pricing

**LEAD TIMES**

**15-20 WORK DAYS - STD**

**10 DAY RUSH ADD 10%**

**5 DAY RUSH ADD 20%**

\*QUANTITY DISCOUNTS START AT \$2700 LIST PRICE, CONTACT THE "FAN DEPT."